

Clausing Radial Drills

600Group

*Celebrating 105 Years in
the Machine Tool Business*

*A Line of Precision Heavy-Duty,
Large Capacity Radial Drills*



- Drilling Capacity up to 3.15" in Steel
3.94" in Cast Iron
- Tapping Capacity up to 2.56" in Steel
2.95" in Cast Iron
- Boring Capacity up to 6" in Steel
10" in Cast Iron



Clausing Radial Drills Models: CL720A

Features and Standard Equipment:

- Limit switch
- High speed gears are made of Nickel-Chrome Steel and are heat-treated and ground for durability
- Powerful 2 Hp spindle drive motor for heavy-duty cutting
- Extra auxiliary dial for spindle feed depth indication, allows review of spindle feed depth, .0394" to 7.874"
- Special spindle balance mechanism, superior to traditional balance mechanism and extends Balance Spring life
- Coolant system
- Low volt and overload protection
- 230/3/60 volt standard ● Tool kit and manuals

Specifications:

Model	CL720A
Working Area:	
Column Sleeve Dia. (E)	8.28" (210mm)
Column Face to Spindle Center Maximum (D+C)	29.5" (750mm)
Minimum (D)	8.7" (220mm)
Spindle Head Travel (C)	20.8" (530mm)
Base Surface to Spindle End Maximum (A)	41.7" (1060mm)
Minimum (B)	10.2" (260mm)
Arm Vertical Travel (A-B)	31.5" (800mm)
Arm Rotation (Right & Left)	180°
Baseplate Working Surface	35.5" x 25.3" (902x643mm)
Box Table Area Length (L)	23.6" (600mm)
Width (K)	17.5" (445mm)
Height (H)	15" (382mm)
Base Dimensions Floor Area (R x S)	49.6" x 25.2" (1260x640mm)
Height (Q)	6.5" (163mm)

Drill Head:	
Spindle Taper	4MT
Spindle Stroke	8.66" (220mm)
Quill Diameter	2.95" (75mm)
Number of Spindle Speeds	6
Spindle Speeds (rpm)	88, 154, 282, 455, 796, 1500
Number of Feeds	3
Spindle Feed Rate (in/rev.)	0.002"/0.0035"/0.006"
(mm/rev.)	.05mm/.09mm/.15mm
Spindle Drive Motor	2 hp (1.5 Kw)
Elevating Motor	1 hp (.75 Kw)
Coolant Pump Motor	1/8 hp (.10 Kw)

Dimensions and Weights:	
Max. Machine Height (F)	85.4" (2170mm)
Base and Column Height (G)	72.8" (1850mm)
Shipping Dim. Length	66.1" (1680mm)
Width	32.5" (826mm)
Height	85" (2160mm)
Net Weight	2,469 lbs. (1120kg)
Shipping Weight	2,756 lbs. (1250kg)

Dimensions:

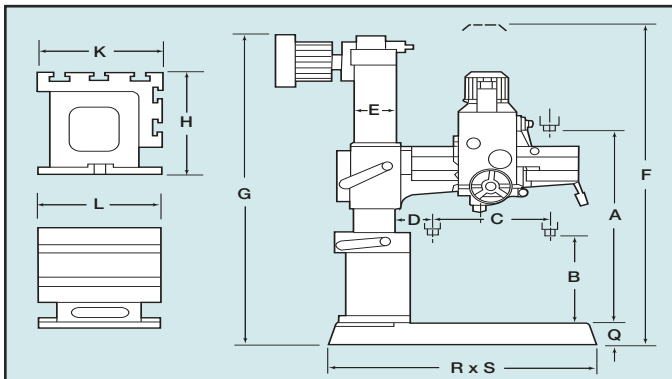

Capacities:

Model	CL720A
Capacity:	
Drilling In Steel	1.26" (32mm)
In Cast Iron	2" (50mm)
Tapping In Steel	1" (25mm)
In Cast Iron	1.26" (32mm)
Boring In Steel	2.75" (70mm)
In Cast Iron	4.06" (105mm)



Clausing Radial Drills

Models: CL820A

Features and Standard Equipment:

- Limit switch
- High speed gears are made of Nickel-Chrome Steel and are heat-treated and ground for durability
- Powerful 2 Hp spindle drive motor for heavy-duty cutting
- Extra auxiliary dial for spindle feed depth indication, allows review of spindle feed depth, .0394" to 7.874"
- Special spindle balance mechanism, superior to traditional balance mechanism and extends Balance Spring life
- Coolant system
- Low volt and overload protection
- 230/3/60 volt standard ● Tool kit and manuals

Specifications:

Model	CL820A
Working Area:	
Column Sleeve Dia. (E)	8.28" (210mm)
Column Face to Spindle Center	
Maximum (D+C)	33.5" (850mm)
Minimum (D)	8.7" (220mm)
Spindle Head Travel (C)	24.8" (630mm)
Base Surface to Spindle End	
Maximum (A)	47.6" (1270mm)
Minimum (B)	13.8" (350mm)
Arm Vertical Travel (A-B)	33.8" (858mm)
Arm Rotation (Right & Left)	180°
Baseplate Working Surface	35.5" x 25.3" (902x643mm)
Box Table Area	
Length (L)	23.6" (600mm)
Width (K)	17.5" (445mm)
Height (H)	15" (382mm)
Base Dimensions	
Floor Area (R x S)	49.6" x 25.2" (1260x640mm)
Height (Q)	6.5" (163mm)

Dimensions:

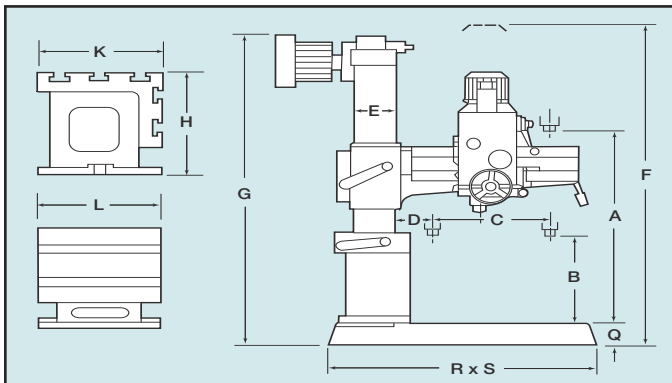

Drill Head:

Spindle Taper	4MT
Spindle Stroke	8.66" (220mm)
Quill Diameter	2.95" (75mm)
Number of Spindle Speeds	6
Spindle Speeds (rpm)	88, 154, 282, 455, 796, 1500
Number of Feeds	3
Spindle Feed Rate (in/rev.)	0.002" 0.0035" 0.006"
	.05mm), (.09mm), (.15mm)
Spindle Drive Motor	2 hp (1.5 Kw)
Elevating Motor	1 hp (.75 Kw)
Coolant Pump Motor	1/8 hp (.10 Kw)

Capacities:

Model	CL820A
Capacity:	
Drilling	
In Steel	1.26" (32mm)
In Cast Iron	2" (50mm)
Tapping	
In Steel	1" (25mm)
In Cast Iron	1.26" (32mm)
Boring	
In Steel	2.75" (70mm)
In Cast Iron	4.06" (105mm)

Dimensions and Weights:

Max. Machine Height (F)	91.3" (2170mm)
Base and Column Height (G)	79.1" (2010mm)
Shipping Dim.	
Length	66.1" (1680mm)
Width	32.5" (826mm)
Height	86.2" (2190mm)
Net Weight	2,645 lbs. (1200kg)
Shipping Weight	2,954 lbs. (1340kg)



Clausing Radial Drills Models: CL920A

Features and Standard Equipment:

- Limit switch
- High speed gears are made of Nickel-Chrome Steel and are heat-treated and ground for durability
Powerful 2 Hp spindle drive motor for heavy-duty cutting
- Extra auxiliary dial for spindle feed depth indication, allows review of spindle feed depth, .0394" to 7.874"
- Special spindle balance mechanism, superior to traditional balance mechanism and extends Balance Spring life
- Coolant system
- Low volt and overload protection
- 230/3/60 volt standard ● Tool kit and manuals

Specifications:

Model	CL920A
Working Area:	
Column Sleeve Dia. (E)	8.28" (210mm)
Column Face to Spindle Center Maximum (D+C)	37.4" (950mm)
Minimum (D)	8.7" (220mm)
Spindle Head Travel (C)	28.7" (730mm)
Base Surface to Spindle End Maximum (A)	47.6" (1210mm)
Minimum (B)	13.8" (350mm)
Arm Vertical Travel (A-B)	33.8" (858mm)
Arm Rotation (Right & Left)	180°
Baseplate Working Surface	35.5" x 25.3" (902x643mm)
Box Table Area Length (L)	23.6" (600mm)
Width (K)	17.5" (445mm)
Height (H)	15" (382mm)
Base Dimensions Floor Area (R x S)	49.6" x 25.2" (1260x640mm)
Height (Q)	6.5" (163mm)

Drill Head:	
Spindle Taper	4MT
Spindle Stroke	8.66" (220mm)
Quill Diameter	2.95" (75mm)
Number of Spindle Speeds	6
Spindle Speeds (rpm)	88, 154, 282, 455, 796, 1500
Number of Feeds	3
Spindle Feed Rate (in/rev.)	0.002"/0.0035"/0.006"
(mm/rev.)	.05mm/.09mm/.15mm
Spindle Drive Motor	2 hp (1.5 Kw)
Elevating Motor	1 hp (.75 Kw)
Coolant Pump Motor	1/8 hp (.10 Kw)

Dimensions and Weights:	
Max. Machine Height (F)	91.3" (2320mm)
Base and Column Height (G)	79.1" (2010mm)
Shipping Dim. Length	71.1" (1806mm)
Width	32.5" (826mm)
Height	86.2" (2190mm)
Net Weight	2,756 lbs. (1250kg)
Shipping Weight	3,086 lbs. (1400kg)

Dimensions:

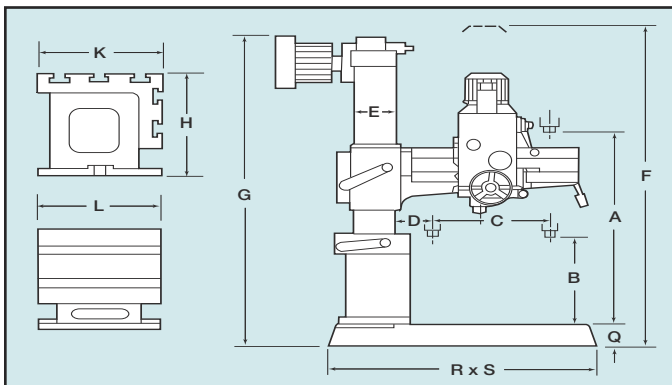

Capacities:

Model	CL920A
Capacity:	
Drilling In Steel	1.26" (32mm)
In Cast Iron	2" (50mm)
Tapping In Steel	1" (25mm)
In Cast Iron	1.26" (32mm)
Boring In Steel	2.75" (70mm)
In Cast Iron	4.06" (105mm)



Clausing Radial Drills Model: CL1100

Features and Standard Equipment:

- High-quality cast-iron arm with heat-treated and ground slides for smooth and accurate head positioning
- The bearing bracket for gear-box is fitted with standard bearings to fit arm slide for smooth gear-box operation
- High speed gears are made of Nickel-Chrome Steel and are heat-treated and ground for durability
- Powerful 3 Hp, 2-speed, heavy-duty spindle drive motor
Overload protection device
- The main spindle is balanced by a specially shaped spring
Coolant system
- Low volt and overload protection
- Tool kit and manuals
- 230/3/60 volt standard or other voltages require optional transformer or special order

Specifications:

Model	CL1100
Working Area:	
Column Sleeve Dia. (E)	10.24" (260mm)
Column Face to spindle Center Maximum (D+C)	43.3" (1100mm)
Minimum (D)	11.0" (280mm)
Spindle Head Travel (C)	32.3" (820mm)
Base Surface to Spindle End Maximum (A)	50.0" (1270mm)
Minimum (B)	18.5" (470mm)
Arm Vertical Travel (A-B)	31.5" (800mm)
Arm Rotation (Right & Left)	180°
Baseplate Working Surface	48" x 29.1"(1219 x 739mm)
Box Table Area	
Length (L)	25.1" (640mm)
Width (K)	20.4" (520mm)
Height (H)	16.5" (420mm)
Base Dimensions	
Floor Area (R x S)	67.9" x 28.1"(1725 x 715mm)
Height (Q)	7.1"(180mm)

Dimensions:

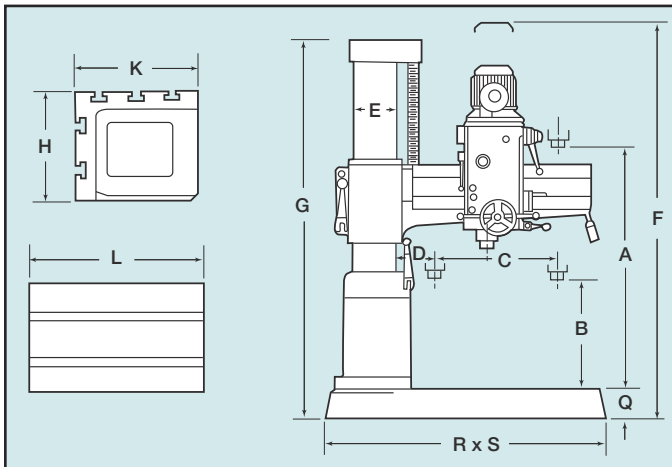

Drill Head:

Spindle Taper	4MT
Spindle Stroke	9.05" (230mm)
Quill Diameter	3.15" (80mm)
Number of Spindle Speeds	12
Spindle Speeds (rpm)	44-1500
Number of Feeds	3
Spindle Feed Rate (in/mm)/rev.)	0.002"(.05mm), 0.0035"(.09mm), 0.006"(.15mm)
Spindle Drive Motor (2-speed)	3 hp (2.25 Kw)
Elevating Motor	1 hp (.75 Kw)
Coolant Pump Motor	1/8 hp (.10 Kw)

Capacities:

Model	CL1100
Capacity:	
Drilling	
In Steel	1.65" (42mm)
In Cast Iron	2.16" (55mm)
Tapping	
In Steel	1" (25mm)
In Cast Iron	1.5" (38mm)
Boring	
In Steel	3.35" (85mm)
In Cast Iron	4.72" (120mm)

Dimensions and Weights:

Max. Machine Height (F)	99.6" (2530mm)
Base and Column Height (G)	78.7" (2000mm)
Shipping Dim.	
Length	74.0" (1880mm)
Width	34.0" (864mm)
Height	87" (2210mm)
Net Weight	3,968 lbs. (1800kg)
Shipping Weight	4,299 lbs. (1950kg)



Clausing Radial Drills

Model: CL1230H

Features and Standard Equipment:

- High-quality cast-iron arm with heat-treated and ground slides for smooth and accurate head positioning
- The bearing bracket for gear-box is fitted with standard bearings to fit arm slide for smooth gear-box operation
- High speed gears are made of Nickel-Chrome Steel and are heat-treated and ground for durability
- Powerful 3 Hp, 2-speed, heavy-duty spindle drive motor
- Overload protection device
- The main spindle is balanced by an adjustable block
- Coolant system
- Low volt and overload protection
- Equipped with hydraulic clamping. With a push of a button you can have arm unclamped then move vertically, or stop then clamp automatically
- Tool kit and manuals
- 230/3/60 volt standard or other voltages require optional transformer or special order

Specifications:

Model	CL1230H
Working Area:	
Column Sleeve Dia. (E)	11.81" (300mm)
Column Face to Spindle Center Maximum (D+C)	46.1" (1170mm)
Minimum (D)	13.4" (340mm)
Spindle Head Travel (C)	35.0" (890mm)
Base Surface to Spindle End Maximum (A)	53.9" (1370mm)
Minimum (B)	19.3" (490mm)
Arm Vertical Travel (A-B)	34.6" (880mm)
Arm Rotation (Right & Left)	180°
Baseplate Working Surface	48" x 29.1"(1219 x 739mm)
Box Table Area	
Length (L)	25.1" (640mm)
Width (K)	20.4" (520mm)
Height (H)	16.5" (420mm)
Base Dimensions	
Floor Area (R x S)	67.9" x 28.1"(1725 x 715mm)
Height (Q)	7.1" (180mm)

Dimensions:

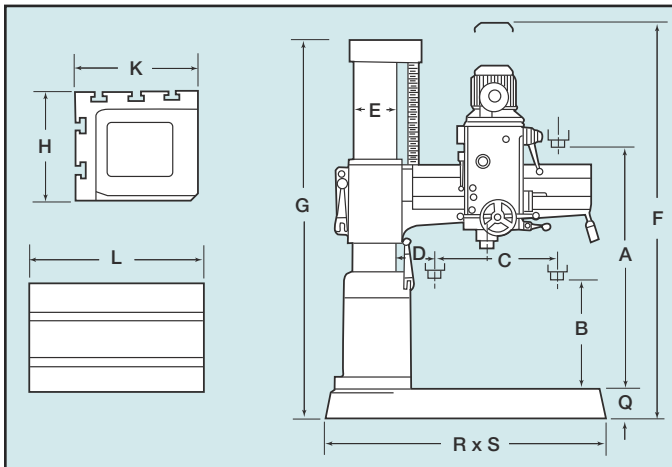

Drill Head:

Spindle Taper	4MT
Spindle Stroke	9.84" (250mm)
Quill Diameter	3.15" (80mm)
Number of Spindle Speeds	2
Spindle Speeds (rpm)	44-1500
Number of Feeds	3
Spindle Feed Rate (in(mm)/rev.)	0.002"(.05mm), 0.0035"(.09mm), 0.006"(.15mm)
Spindle Drive Motor (2-speed)	3 hp (2.25 Kw)
Elevating Motor	1 hp (.75 Kw)
Clamping Motor	1 hp (.75 Kw)
Coolant Pump Motor	1/8 hp (.10 Kw)

Capacities:

Model	CL1230H
Capacity:	
Drilling	
In Steel	1.65" (42mm)
In Cast Iron	2.16" (55mm)
Tapping	
In Steel	1" (25mm)
In Cast Iron	1.38" (38mm)
Boring	
In Steel	3.38" (86mm)
In Cast Iron	4.72" (120mm)

Dimensions and Weight:

Max. Machine Height (F)	109.5" (2780mm)
Base and Column Height (G)	81.1" (2060mm)
Shipping Dim.	
Length	80.1" (2035mm)
Width	32.5" (862mm)
Height	88.2" (2240mm)
Net Weight	4,630 lbs. (2100kg)
Shipping Weight	5,071 lbs. (2300kg)



Shown with Optional Tilt Table

Clausing Radial Drills

Model: CLC1250H

Features and Standard Equipment:

- Equipped with hydraulic separate clamping unit. Vertical movement of arm is coordinated by an IC timer. With a single touch on push button switch, you can have the arm unclamped then move vertically, or stop then clamp automatically. Very easy to operate, and tools will always stay at the same point after tool shifting
- Gears in gear box are cooled by oil cycled by an oil pump to minimize gear wear
- Powerful 5 Hp, 2-speed, heavy-duty spindle drive motor
- Friction type disc clutch absorbs impact force caused by vertical movement of spindle, and protects all transmission units inside gear box. With quick spindle return, the clutch will help speed-up the tapping operation
- Special arm elevating device is provided to prevent arm from falling down abruptly after years of usage
- Coolant system ● Tool kit and manuals
- 230/3/60 volt standard or other voltages require optional transformer or special order

Specifications:

Model	CLC1250H
Working Area:	
Column Sleeve Dia. (E)	11.81" (300mm)
Column Face to Spindle Center	
Maximum (D+C)	49.21" (1250mm)
Minimum (D)	14.17" (360mm)
Spindle Head Travel (C)	35.04" (890mm)
Base Surface to Spindle End	
Maximum (A)	52.95" (1345mm)
Minimum (B)	17.36" (441mm)
Arm Vertical Travel (A-B)	28.1" (715mm)
Arm Rotation (Right & Left)	180°
Baseplate Working Surface	48" x 29.1"(1219 x 739mm)
Box Table Area	
Length (L)	25.1" (640mm)
Width (K)	20.4" (520mm)
Height (H)	16.5" (420mm)
Base Dimensions	
Floor Area (R x S)	70.3" x 30.9"(1785 x 785mm)
Height (Q)	7.8" (190mm)

Dimensions:

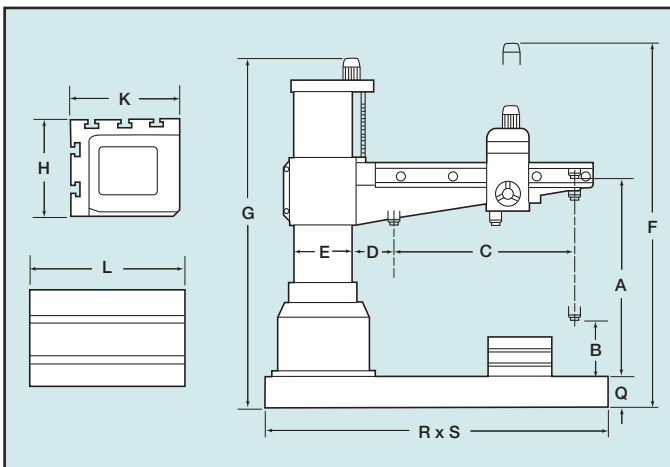

Capacities:

Model	CLC1250H
Capacity:	
Drilling	
In Steel	1.97" (50mm)
In Cast Iron	2.36" (60mm)
Tapping	
In Steel	1.57" (40mm)
In Cast Iron	1.97" (50mm)
Boring	
In Steel	4.33" (110mm)
In Cast Iron	6.55" (165mm)

Drill Head:

Spindle Taper	5MT
Spindle Stroke	10.63" (270mm)
Quill Diameter	3.15" (80mm)
Number of Spindle Speeds	12
Spindle Speeds (rpm)	56-1450
Number of Feeds	3
Spindle Feed Rate (in/mm)/rev.)	0.0023"(.06mm), 0.004"(.10mm), 0.008"(.20mm)
Spindle Drive Motor (2-speed)	5 hp (3.8 Kw)
Elevating Motor	1 hp (.75 Kw)
Clamping Motor	1 hp (.75 Kw)
Coolant Pump Motor	1/8 hp (.10 Kw)

Dimensions and Weight:

Max. Machine Height (F)	104.1" (2645mm)
Base and Column Height (G)	81.9" (2080mm)
Shipping Dim.	
Length	81.1" (2060mm)
Width	39.2" (995mm)
Height	88.2" (2240mm)
Net Weight	5,071 lbs. (2300kg)
Shipping Weight	5,512 lbs. (2500kg)



Shown with Optional Tilt Table

Dimensions:

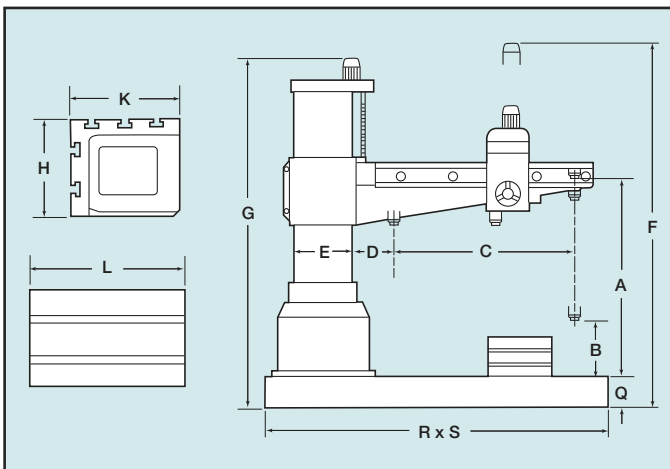

Capacities:

Model	CLC1600H
Capacity:	
Drilling	
In Steel	1.97" (50mm)
In Cast Iron	2.36" (60mm)
Tapping	
In Steel	1.57" (40mm)
In Cast Iron	1.97" (50mm)
Boring	
In Steel	4.33" (110mm)
In Cast Iron	6.55" (165mm)

Clausing Radial Drills

Model: CLC1600H

Features and Standard Equipment:

- Equipped with hydraulic separate clamping unit. Vertical movement of arm is coordinated by an IC timer. With a single touch on push button switch, you can have the arm unclamped then move vertically, or stop then clamp automatically. Very easy to operate, and tools will always stay at the same point after tool shifting
- Gears in gear box are cooled by oil cycled by an oil pump to minimize gear wear
- Powerful 5 Hp, 2-speed, heavy-duty spindle drive motor
- Friction type disc clutch absorbs impact force caused by vertical movement of spindle, and protects all transmission units inside gear box. With quick spindle return, the clutch will help speed-up the tapping operation
- Special arm elevating device is provided to prevent arm from falling down abruptly after years of usage
- Coolant system ● Tool kit and manuals
- 230/3/60 volt standard or other voltages require optional transformer or special order

Specifications:

Model	CLC1600H
Working Area:	
Column Sleeve Dia. (E)	12.61" (320mm)
Column Face to Spindle Center	
Maximum (D+C)	63.00" (1600mm)
Minimum (D)	13.78" (350mm)
Spindle Head Travel (C)	49.21" (1250mm)
Base Surface to Spindle End	
Maximum (A)	55.90" (1420mm)
Minimum (B)	18.31" (465mm)
Arm Vertical Travel (A-B)	36.7" (932mm)
Arm Rotation (Right & Left)	180°
Baseplate Working Surface	70.9" x 40.4" (1800 x 1026mm)
Box Table Area	
Length (L)	24.8" (630mm)
Width (K)	19.7" (500mm)
Height (H)	19.7" (500mm)
Base Dimensions	
Floor Area (R x S)	100.4" x 38.2" (2550 x 970mm)
Height (Q)	7.9" (200mm)

Drill Head:

Spindle Taper	5MT
Spindle Stroke	10.63" (270mm)
Quill Diameter	3.15" (80mm)
Number of Spindle Speeds	12
Spindle Speeds (rpm)	56-1450
Number of Feeds	3
Spindle Feed Rate (in/mm)/rev.)	0.0023"(.06mm), 0.004"(.10mm), 0.008"(.20mm)
Spindle Drive Motor (2-speed)	5 hp (3.8 Kw)
Elevating Motor	1 hp (.75 Kw)
Clamping Motor	1 hp (.75 Kw)
Coolant Pump Motor	1/8 hp (.10 Kw)

Dimensions and Weight:

Max. Machine Height (F)	108.7" (2760mm)
Base and Column Height (G)	86.1" (2186mm)
Shipping Dim.	
Length	105.2" (2670mm)
Width	44.1" (1120mm)
Height	94.9" (2410mm)
Net Weight	7,275 lbs. (3300kg)
Shipping Weight	8,378 lbs. (2800kg)



Clausing Radial Drills

Model: CL1600H

Features and Standard Equipment:

- Equipped with hydraulic separate clamping unit. Vertical movement of arm is coordinated by an IC timer. With a single touch on push button switch, you can have the arm unclamped then move vertically, or stop then clamp automatically. Very easy to operate, and tools will always stay at the same point after tool shifting.
- Gears in gear box are cooled by oil cycled by an oil pump to minimize gear wear.
- Friction type disc clutch absorbs impact force caused by vertical movement of spindle, and protects all transmission units inside gear box. With quick spindle return, the clutch will help speed-up the tapping operation.
- Special automatic tool eject device is supplied to allow you to change tools quickly. (No drifter is required) Special arm elevating device is provided to prevent arm from falling down abruptly after.
- Coolant system ● Tool kit and manuals
- 230/3/60 volt standard

Specifications:

Dimensions:

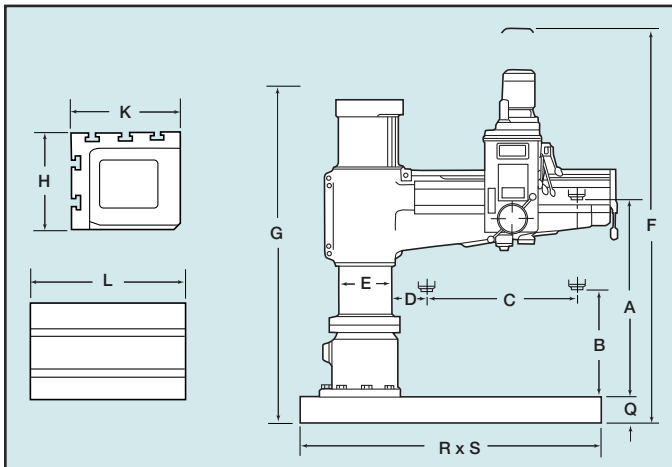

Model	CL1600H
Working Area:	
Column Sleeve Dia. (E)	17" (432mm)
Column Face to Spindle Center	
Maximum (D+C)	62.2" (1580mm)
Minimum (D)	17.3" (440mm)
Spindle Head Travel (C)	44.9" (1140mm)
Base Surface to Spindle End	
Maximum (A)	63" (1600mm)
Minimum (B)	15" (380mm)
Arm Vertical Travel (A-B)	48" (1220mm)
Arm Rotation (Right & Left)	180°
Baseplate Working Surface	70.9" x 40.4" (1800 x 1026mm)
Box Table Area	
Length (L)	27.6" (700mm)
Width (K)	19.7" (500mm)
Height (H)	15.9" (405mm)
Base Dimensions	
Floor Area (R x S)	97.6" x 41.3" (2480 x 1050mm)
Height (Q)	8.26" (210mm)
Drill Head:	
Spindle Taper	5MT
Spindle Stroke	14.6" (370mm)
Quill Diameter	3.94" (100mm)
Number of Spindle Speeds	12
Spindle Speeds (rpm)	40-1920
Number of Steps	6
Spindle Feed Rate (in(mm)/rev.)	0.003"(.07mm)-0.038"(.96mm)
Spindle Drive Motor (1-speed)	7.5 hp (5.6 Kw)
Elevating Motor	2 hp (1.5 Kw)
Clamping Motor	1 hp (.75 Kw)
Coolant Pump Motor	1/8 hp (.10 Kw)
Dimensions and Weight	
Max. Machine Height (F)	124.8" (3170mm)
Base and Column Height (G)	107.7" (2660mm)
Shipping Dim.	
Length	112.2" (2850mm)
Width	55.1" (1400mm)
Height	115.7" (2940mm)
Net Weight	10,805 lbs. (4900kg)
Shipping Weight	11,245 lbs. (5100kg)

Capacities:

Model	CL1600H
Capacity:	
Drilling	
In Steel	2.6" (65mm)
In Cast Iron	2.75" (70mm)
Tapping	
In Steel	1.97" (50mm)
In Cast Iron	2.36" (60mm)
Boring	
In Steel	5" (126mm)
In Cast Iron	7.28" (185mm)



Clausing Radial Drills

Model: CL2000H

Features and Standard Equipment:

- Equipped with hydraulic separate clamping unit. Vertical movement of arm is coordinated by an IC timer. With a single touch on push button switch, you can have the arm unclamped then move vertically, or stop then clamp automatically. Very easy to operate, and tools will always stay at the same point after tool shifting. Gears in gear box are cooled by oil cycled by an oil pump to minimize gear wear.
- Friction type disc clutch absorbs impact force caused by vertical movement of spindle, and protects all transmission units inside gear box. With quick spindle return, the clutch will help speed-up the tapping operation.
- Special arm elevating device is provided to prevent arm from falling down abruptly after years of usage.
- Coolant system
- Tool kit and manuals
- 230/3/60 volt standard

Specifications:

Dimensions:

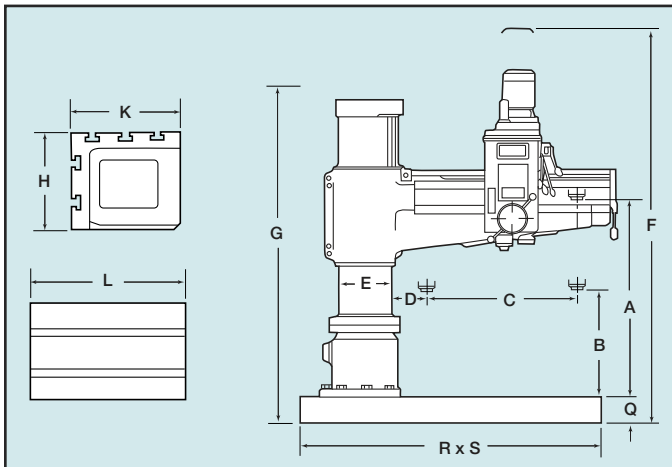

Model	CL2000H
Working Area:	
Column Sleeve Dia. (E)	17" (432mm)
Column Face to Spindle Center	
Maximum (D+C)	78.7" (2000mm)
Minimum (D)	19.3" (490mm)
Spindle Head Travel (C)	59.4" (1510mm)
Base Surface to Spindle End	
Maximum (A)	74.8" (1900mm)
Minimum (B)	19.7" (500mm)
Arm Vertical Travel (A-B)	55.1" (1400mm)
Arm Rotation (Right & Left)	180°
Baseplate Working Surface	
Box Table Area	
Length (L)	39.3" (1000mm)
Width (K)	31.5" (800mm)
Height (H)	19.7" (500mm)
Base Dimensions	
Floor Area (R x S)	114.5" x 43.3" (2908 x 1102mm)
Height (Q)	98.4" (250mm)

Capacities:

Model	CL2000H
Capacity:	
Drilling	
In Steel	2.6" (65mm)
In Cast Iron	2.75" (70mm)
Tapping	
In Steel	1.97" (50mm)
In Cast Iron	2.36" (60mm)
Boring	
In Steel	5" (126mm)
In Cast Iron	7.28" (185mm)

Drill Head:	
Spindle Taper	5MT
Spindle Stroke	14.6" (370mm)
Quill Diameter	3.94" (100mm)
Number of Spindle Speeds	12
Spindle Speeds (rpm)	35-1890
Number of Steps	6
Spindle Feed Rate (in(mm)/rev.)	0.003"(.07mm)-0.038"(.96mm)
Spindle Drive Motor (1-speed)	7.5 hp (5.6 Kw)
Elevating Motor	3 hp (2.25 Kw)
Clamping Motor	1 hp (.75 Kw)
Coolant Pump Motor	1/8 hp (.10 Kw)

Dimensions and Weight	
Max. Machine Height (F)	124.8" (3470mm)
Base and Column Height (G)	116.5" (2960mm)
Shipping Dim.	
Length	122.2" (3105mm)
Width	55.1" (1400mm)
Height	127.5" (3240mm)
Net Weight	13,448 lbs. (6100kg)
Shipping Weight	14,550 lbs. (6600kg)



Clausing Radial Drills

Model: CLC2500

Features and Standard Equipment:

- Equipped with hydraulic separate clamping unit. Vertical movement of arm is coordinated by an IC timer. With a single touch on push button switch, you can have the arm unclamped then move vertically, or stop then clamp automatically. Very easy to operate, and tools will always stay at the same point after tool shifting
- Gears in gear box are cooled by oil cycled by an oil pump to minimize gear wear
- Friction type disc clutch absorbs impact force caused by vertical movement of spindle, and protects all transmission units inside gear box. With quick spindle return, the clutch will help speed-up the tapping operation
- Special arm elevating device is provided to prevent arm from falling down abruptly after years of usage
- Coolant system
- Tool kit and manuals
- 230/3/60 volt standard

Specifications:

Model	CLC2500
Working Area:	
Column Sleeve Dia. (E)	21.65" (550mm)
Column Face to Spindle Center	
Maximum (D+C)	98.4" (2500mm)
Minimum (D)	19.7" (500mm)
Spindle Head Travel (C)	78.7" (2000mm)
Base Surface to Spindle End	
Maximum (A)	78.7" (2000mm)
Minimum (B)	21.6" (550mm)
Arm Vertical Travel (A-B)	57.1" (1450mm)
Arm Rotation (Right & Left)	180°
Baseplate Working Surface	86.8" x 43.4" (2205 x 1102mm)
Box Table Area	
Length (L)	39.4" (1000mm)
Width (K)	31.5" (800mm)
Height (H)	22" (560mm)
Base Dimensions	
Floor Area (R x S)	138.6" x 55.1" (3520 x 1400mm)
Height (Q)	12.6" (320mm)
Drill Head:	
Spindle Taper	6MT
Spindle Stroke	17.7" (450mm)
Quill Diameter	3.94" (100mm)
Number of Spindle Speeds	16
Spindle Speeds (rpm)	16-1250
Number of Steps	16
Spindle Feed Rate (in/mm)/rev.)	0.0015"(.04mm)-0.126"(3.20mm)
Spindle Drive Motor (1-speed)	10 hp (7.5 Kw)
Elevating Motor	5 hp (3.6 Kw)
Coolant Pump Motor	1/4 hp (.18 Kw)
Dimensions and Weight:	
Max. Machine Height (F)	157" (3990mm)
Base and Column Height (G)	151.6" (2660mm)
Shipping Dim.	
Length	158" (4000mm)
Width	63" (1600mm)
Height	151.6" (3850mm)
Net Weight	24,250 lbs. (11000kg)
Shipping Weight	27,557 lbs. (12500kg)

Dimensions:

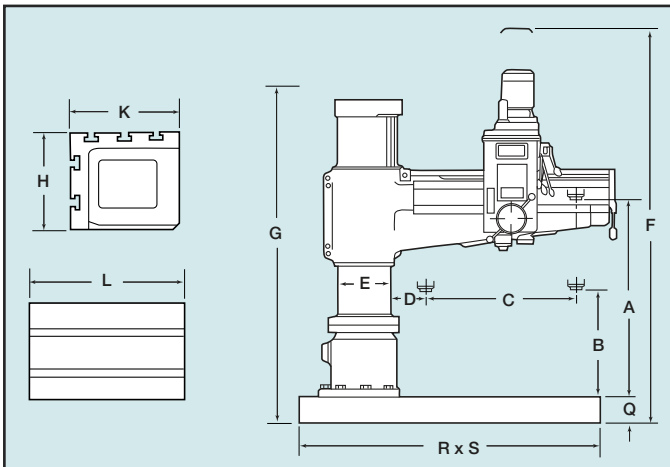

Capacities:

Model	CLC2500
Capacity:	
Drilling	
In Steel	3.15" (80mm)
In Cast Iron	3.98" (100mm)
Tapping	
In Steel	2.56" (65mm)
In Cast Iron	2.95" (75mm)
Boring	
In Steel	6" (150mm)
In Cast Iron	10" (250mm)



Your Single Source for Machine Tools

Clausing Precision Drills

- Clausing Belt-drive Drills
- Clausing Geared-head Drills
- Clausing Radial Drills

Clausing Precision Mills

- Clausing Bed Mills
- Clausing CNC Bed Mills
- Clausing Knee Mills
- Clausing EVS Knee Mills
- Clausing Universal Mills

Clausing Precision Lathes

- Clausing/Colchester Geared Head Lathes
- Clausing/Colchester Professional V.S. Lathes
- Clausing/Colchester MAGNUM V.S. Lathes
- Clausing MA/MAV Series Lathes
- Clausing Large Swing Standard vLathes
- Clausing Large Swing CNC Lathes

Clausing Precision Grinders

- Clausing Manual Grinders
- Clausing 2 Axes Hydraulic Grinders
- Clausing 3 Axes Hydraulic Grinders
- Clausing ASDIII Automatic Grinders

Clausing Precision Cutting Machines

- Clausing/Kalamazoo Horizontal Bandsaws
- Clausing/Kalamazoo Vertical Bandsaws
- Clausing/Kalamazoo Tilt Frame Miter Bandsaws
- Clausing/Kalamazoo Cold Saws

For detailed catalogs of the full line of Clausing Machine Tools visit our Web Site:

www.clausing-industrial.com

Fax: 269-345-5945 or e-mail us and request an electronic (pdf) catalog at:

info@clausing-industrial.com

Your Authorized Clausing Precision Machine Tools Distributor



Call 800-323-0972 for the Clausing Dealer Nearest You
or visit www.clausing-industrial.com

Celebrating Over A Century in the Machine Tool Business