



*Celebrating Over 102 Years
in the Machine Tool Business*

Horizontal Bandsaws

*A Complete Line of Precision General
Purpose Horizontal Bandsaws*



**Precision Manual Bandsaws
Precision Semi-Automatic Bandsaws
Precision Fully-Automatic Bandsaws**

Clausing/Kalamazoo 8" (200mm) Wet Cutting Bandsaw

Features:

- 1 Hp (.75kw) drive motor with magnetic starter and overload protection
- 4 speed step pulley with worm gear speed reducer, worm shaft is hardened and ground
- Totally enclosed transmission
- Heavy-duty hydraulic cylinder with precision ground hinge support
- Pan shaped base with built-in coolant & hydraulic system
- Cast iron bed
- Carbide blade guides with roller bearings
- Two additional bearings to support blade from the top
- Integral coolant system
- Blade brush
- Valve controlled hydraulic cylinder control feed can be adjusted for different types and sizes of material
- Adjustable stock stop
- Simplified control switches mounted on saw head
- Cast iron 0°- 45° vise with manual leadscrew clamping system
- Anti-slip hand wheel
- Easy blade change with front access at waist level
- 1" wide bi-metal saw blade
- Operation & parts manual
- Two (2) year limited warranty

Accessories

- BT01 Bandsaw Blade Tension Gauge
- P10 Stock Stand Assembly 21" - 30"
- SA8 Roller Table Assembly 10' x 15"
- SA9 Roller Table Assembly 5' x 15"
- BT01 Bandsaw Blade Tension Gauge
- CSR1 SAWZIT 1 Gallon
- CSR5 SAWZIT 5 Gallon



Specifications

Model	KC812W
Type	Horizontal wet cut
Drive Motor	1 Hp (.75kw) 110v or 220v 1 Ph
Band Wheel Diameter	11.5" (292mm) Flanged, Cast Iron
Blade Size	1" x .035" x 8'-11" (27 x .9 x 2720mm)
Bed Height	24.8" (639mm)
Blade Speeds (4)	59, 96, 155, 260 fpm (18, 29, 47, 79 m/min)
90° Cutting Capacity	
Round	8" (190mm)
Square	7" (180mm)
Rectangular (H x W)	7" x 14" (180 x 355mm)
45° Cutting Capacity	
Round	7.5" (200mm)
Square	6" (152mm)
Rectangular (H x W)	6" x 9" (152 x 228mm)
Width	59" (1500mm)
Depth	24.6" (625mm)
Height (head-up)	63" (1600mm)
Height (head-down)	45" (1150mm)
Net Weight	484 lbs. (220kg)
Shipping Weight	580 lbs. (263kg)
Shipping Dim. (LxWxH)	58" x 30" x 48" (1475 x 762 x 1220mm)

Design and specifications are subject to change without notice.

Clausing/Kalamazoo 10" (250mm) Wet Cutting Bandsaw

Features:

- 2 Hp (1.5kw) drive motor 230v & 460v 3 Ph models and 1.5 Hp (1.1kw) drive motor on 110v & 220v 1 Ph models
- Magnetic starter with overload protection
- 4 speed step pulley with worm gear speed reducer, worm shaft is hardened and ground (model KC1016W)
- Infinity Variable Speed drive (model KC1016VS)
- Totally enclosed transmission
- Heavy-duty hydraulic cylinder with precision ground hinge support
- Pan shaped base with built-in coolant & hydraulic system
- Cast iron bed
- Cast iron quick acting 0°- 45° vise with manual leadscrew clamping system
- Carbide blade guides with roller bearings
- Two additional bearings to support blade from the top
- Recirculating coolant system with application through both guides
- Blade brush
- Valve controlled hydraulic cylinder controls feed and can be adjusted for different types and sizes of material
- Adjustable stock stop
- Simplified control switches mounted on saw head
- Anti-slip hand wheel
- Easy blade change with front access at waist level
- 1" wide bi-metal saw blade
- Tools
- Operation & parts manual
- Two (2) year limited warranty



Speed control and speed chart on variable speed model KC1016VS

Specifications

Model	KC1016W/KC1016VS
Type	Horizontal wet cut
Motor KC1016W	1.5 Hp (1.1kw) 110v or 220v 1 Ph
4 Speed Drive	2 Hp (1.5kw) 230v or 460v 3 Ph
Motor KC1016VS	1.5 Hp (1.1kw) 110v or 220v 1 Ph
Variable Speed Drive	2 Hp (1.5kw) 230v or 460v 3 Ph
Band Wheel Diameter	15" (381mm) Flanged, Cast Iron
Blade Size	1" x .035" x 11' (27 x .9 x 3350mm)
Bed Height	25" (650mm)
Blade Speeds Step	(4) 75, 121, 190, 305 fpm (23, 37, 58, 93 m/min)
Blade Speeds VS	50-295 fpm (15-90 m/min)
90° Cutting Capacity	
Round	10" (250mm)
Rectangular (H x W)	9" x 14.5" (230 x 368mm)
45° Cutting Capacity	
Round	9" (230mm)
Rectangular (H x W)	9" x 9" (230 x 230mm)
Width	64" (1625mm)
Depth	42" (1067mm)
Height (head-up)	69" (1752mm)
Height (head-down)	41" (1041mm)
Net Weight	800 lbs. (363kg)
Shipping Weight	950 lbs. (432kg)
Shipping Dim. (LxWxH)	67" x 31" x 48" (1700 x 787 x 1220mm)

Accessories

- P10 Stock Stand Assembly 21" - 30"
- SA10 Roller Table Assembly 10' x 18"
- SA11 Roller Table Assembly 5' x 18"
- BT01 Bandsaw Blade Tension Gauge
- CSR1 SAWZIT 1 Gallon
- CSR5 SAWZIT 5 Gallon

Clausing Kalamazoo 10" (254 mm) Wet Cutting Bandsaw

Features:

- 2 Hp (1.5kw) drive motor with magnetic starter and overload protection
- 4 step blade speeds (KT1018W)
- Infinity variable blade speeds (KT1018VS)
- Quick positioning 45° vise
- Cast iron bed
- Totally enclosed transmission
- Quick and simple speed change
- 1" (254mm) wide blade
- Blade cleaning brush
- Solid carbide blade guides with rollers
- Recirculating coolant system with application through both guides
- Stock stop
- Easily adjusted head feed
- Head control is hydraulic cylinder operated by needle valve
- Two (2) year limited warranty



Speed control and speed chart on variable speed model KT1018VS

Specifications:

Model	KT1018W/KT1018VS
Type	Horizontal wet cut
Drive Motor	2 Hp (1.5 kw) 110v or 220v 1 Ph 230v or 460v 3 Ph
Blade Wheel Dia.	15.4" (391 mm) flanged, cast iron
Blade	1" x .035" x 11'-4.5" (27 x .9 x 3465 mm)
Bed Height	21.8" (555mm)
Blade Speeds W model	60, 125, 200, 300 fpm (18, 38, 61, 92 mpm)
Blade Speeds VS model	69 - 321 fpm (21 - 98 mpm)
90° Cutting Capacity	
Round	10" (254mm)
Rectangular	18" x 6" or 16" x 10" (457 x 152 or 406 x 254mm)
45° Cutting Capacity	
Round	8" (203mm)
Rectangular	8" x 6" or 4" x 9" or 3" x 10" (203.2 x 152.4 or 101.6 x 228.6 or 76.2 x 254mm)
Floor Space	61" x 51" (1550 x 1300mm)
Machine Dim. LxWxH	74.8" x 29.1" x 39.4" (1900 x 740 x 1000mm)
Height (head-up)	60.4" (1535mm)
Height (head-down)	39.4" (1000mm)
Net Weight	780 lbs. (350 kg)
Shipping Weight	850 lbs. (385 kg)
Machine Dim. LxWxH	80.3" x 35.4" x 45.3" (2040 x 900 x 1150mm)

Design and specifications are subject to change without notice.

Accessories

- P10 Stock Stand Assembly 21" - 30"
- SA10 Roller Table Assembly 10' x 18"
- SA11 Roller Table Assembly 5' x 18"
- BT01 Bandsaw Blade Tension Gauge

Cutting Capacities:

Capacity at 90°

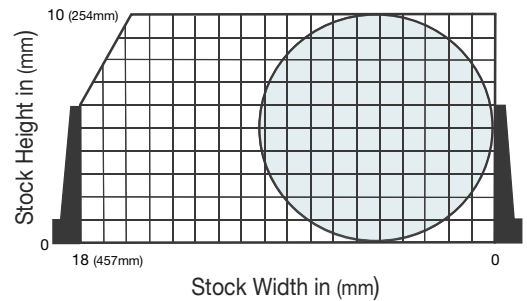

Capacity at 45°

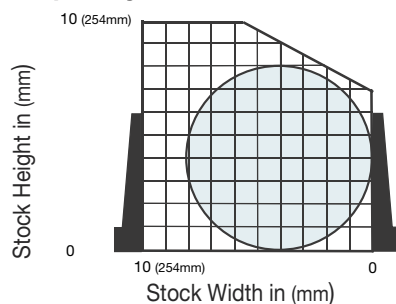



Shown with optional Hydraulic Chip Conveyor

Specifications

Model	KC10AX
Motor	3 Hp (2.2 kw), 230/460v 3ph*
Hydraulic Pump Motor	1 Hp (.75 kw)
Hydraulic Oil Capacity	10.5 gallons (40 liters)
Band Wheel Dia.	15.75" (400 mm)
Blade Speeds (Variable Speed)	66-328 fpm (20-100 m/min)
Blade Size	1.34 x .042" x 11'-6" (34 x 1.1 x 3505mm)
Coolant	Recirculating
Coolant Capacity	16.8 gallons (64 liters)
90° Cutting Capacity	
Round	10" (250 mm)
Rectangular	10" x 11" (250 x 280mm)
Feed Accuracy	±.004" - .008" (±0.1 - 0.2 mm)
Length of Remnant Manual	.59" (15 mm)
Length of Remnant Automatic	1.97" (50 mm)
Minimum Cut Thickness	.354" (9 mm)
**Bundle Cutting Width	6.10" to 7.87" (155 to 200mm)
**Bundle Cutting Height	1.97" to 4.72" (50 to 120mm)
Feed Length/Index	15.75" (400 mm)
Max. Feed (9 times)	141.75" (3600mm)
Length	74" (1890mm)
Width	73" (1850mm)
Height	62" (1580mm)
Bed Height	26" (660mm)
Net Weight	2,660 lbs. (1206 kg)
Shipping Weight	2,830 lbs. (1284 kg)

*Other voltages optional.

**When machine is equipped with optional hydraulic bundle cutting attachment.

Design and specifications are subject to change without notice.

Clausing 10" (250mm) Automatic Bandsaw

Designed for rugged production use, the Clausing KC10AX bandsaw offers high production output and heavy-duty performance in both semi-automatic and fully automatic operation. A powerful drive motor provides the power, and the optional hydraulic bundling attachment makes multiple cuts easy. The hydraulic shuttle feed system offers up to nine indexes.

Features:

- Full or semi-automatic operation
- Infinitely variable blade speeds
- LED blade speed readout
- Vise clamps work piece both sides of blade
- Hydraulic down feed
- Automatic height setting feature
- Auto shutoff at end of material or after preset number of cuts
- Front-mounted digital length gauge
- Blade breakage/stoppage switch
- 110v control circuit
- Overload protection
- Recirculating coolant system
- Shuttle vise
- (1) General purpose bi-metal blade
- Flushing hose for cleanup
- Operator's manual
- Two (2) year limited warranty

Accessories

- BT01 Bandsaw Blade Tension Gauge
- CM1000 Chip Conveyor
- CM1001 Hydraulic Bundle Clamps
- VP1200 Variable Vise Pressure System
- SA20 Heavy-duty Roller Table 10' x 15"
- SA21 Heavy-duty Roller Table 5' x 15"
- P10 Stock Stand Assembly 21" - 30"
- CSR1 SAWZIT 1 Gallon
- CSR5 SAWZIT 5 Gallon

Cutting Capacities:

Capacity at 90°

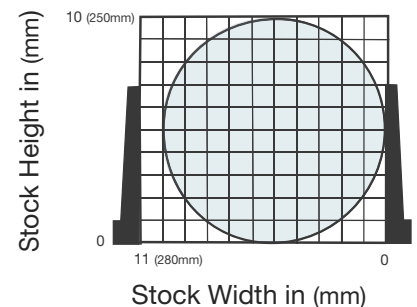

Clausing/Kalamazoo 10" (305mm) Automatic NC Bandsaw

Features:

- Oversized hydraulic cylinder
- Hydraulic shuttle vice assembly
- Inverter controlled infinitely variable speed
- Carbide blade guides with roller bearings
- Two additional guides to support the blade from the top
- Automatic hydraulic blade tensioning
- Power driven blade brushes
- Integral coolant system
- Smart NC-100 technology programmable up to 100 different jobs
- Easy recall and execution of stored parts
- Automatic shutoff after preset number of cuts or when out of stock
- 5.7" HMI touch screen incorporating readout on blade speed, blade life, feed vise position and error code display for self-diagnostics
- Automatic kerf loss compensation & computer controlled multiple indexing
- Precision feed pressure & feed rate
- Bundle/single cutting mode switch
- Automatic height setting feature
- Hydraulic front and rear vises
- Cast iron vises with replaceable hardened wear plates
- Chip Conveyor
- Discharge table with built-in coolant return
- Blade slippage or breakage detection
- Adjustable cut-off stock fence
- Additional flushing hose
- Bi-metal saw blade
- Built in work light
- Tool box, leveling pads, and an additional wire brush
- Operation & parts manual
- Two (2) year limited warranty

Accessories

- BT01 Bandsaw Blade Tension Gauge
- CM1002 Hydraulic Bundle Clamps
- VP1200 Variable Vise Pressure System
- SA20 Heavy-duty Roller Table 10' x 15"
- SA21 Heavy-duty Roller Table 5' x 15"
- P10 Stock Stand Assembly 21" - 30"
- CSR1 SAWZIT 1 Gallon
- CSR5 SAWZIT 5 Gallon



Specifications

Model	KC10NC
Motor	5 Hp (3.75 kw), 230/460v 3ph*
Hydraulic Pump Motor	1 Hp (.75 kw)
Hydraulic Oil Capacity	8.2 gallons (35 liters)
Blade Speeds (Variable Speed)	66-330 fpm (20-100m/min)
Blade Size (W x T x L)	1.25"x.042"x144" (32x1.1x3657mm)
Blade Tension	Hydraulic
Coolant	Recirculating
Coolant Capacity	19.9 gallons (75 liters)
90° Cutting Capacity	
Round	10.2" (260mm)
Square	10.2" (260mm)
Rectangular	11.8" x 10.2" (300 x 260mm)
Feed Accuracy	±.004" - .008" (±0.1 - 0.2 mm)
Length of Remnant Manual	.59" (15 mm)
Length of Remnant Automatic	1.97" (50 mm)
Minimum Cut Thickness	.354" (9 mm)
**Bundle Cutting Width	7.48" to 11.81" (190 to 300mm)
**Bundle Cutting Height	2.0" to 4.7" (50 to 120mm)
Feed Length/Index	15.86" (403mm)
Max. Feed	650" (16510mm)
Length	83" (2108mm)
Width	80" (2032mm)
Height	62" (1530mm)
Bed Height	26" (660mm)
Net Weight	3,300 lbs. (1496 kg)
Shipping Weight	3,750 lbs.(1701 kg)

*Other voltages optional.

**When machine is equipped with optional hydraulic bundle cutting attachment.

Design and specifications are subject to change without notice.



Clausing 12" (305mm) Wet Cutting Semi-Automatic Miter Bandsaw

Features:

- 0°-45° Miter cutting, make angle cuts without swinging material to be cut
- 2 Hp (1.5kw) main drive motor with magnetic starter and overload protection
- Infinitely variable speed drive
- 230/460v 60 cycle 3 phase electricals
- Recirculating coolant system with application through both guides
- Solid carbide blade guides with rollers
- Quick action vise
- Automatic shut-off at end of cut
- Totally enclosed transmission
- Blade cleaning brush
- Cast iron bed
- 1" (254mm) wide blade
- Stock stop
- Easily adjusted head feed with hydraulic power head lift
- Two (2) year limited warranty

Specifications

Model	MS1218VS
Drive Motor	2 Hp (1.5kw) 230/460v 3 phase
Hydraulic Motor	0.25 Hp (.19kw)
Coolant Pump	0.125 Hp (.1kw)
Band Wheel Dia.	15.4" (391mm)
Blade Size	1" x .035" x 11'-4.5" (25 x .9 x 3467mm)
Bed Height	21.75" (552mm)
Vise Opening	18" (457mm)
Blade Speeds	80-360 fpm (24-110 m/min) Variable Speed
90° Cutting Capacity	
Round	12" (305mm)
Square	10" x 10" (254 x 254mm)
Rectangular	10" x 16" (254 x 406mm)
45° Cutting Capacity	
Round	8" (203mm)
Square	8" x 8" (203 x 203mm)
Rectangular	8" x 12" (203 x 305mm)
Width	75" (1905mm)
Depth/with stock stop	34"/49.5" (864/1257)mm
Height (head-up)	64" (1626mm)
Height (head-down)	41" (1041mm)
Net Weight	880 lbs. (400kg)
Shipping Weight	1,100 lbs. (500kg)

Accessories

- P10 Stock Stand Assembly 21" - 30"
- SA12 Roller Table Assembly 10' x 18"
- SA13 Roller Table Assembly 5' x 18"
- BT01 Bandsaw Blade Tension Gauge
- CSR1 SAWZIT 1 Gallon
- CSR5 SAWZIT 5 Gallon

Cutting Capacities:

Capacity at 90°

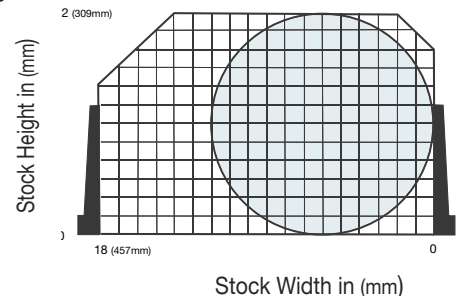

Capacity at 45°

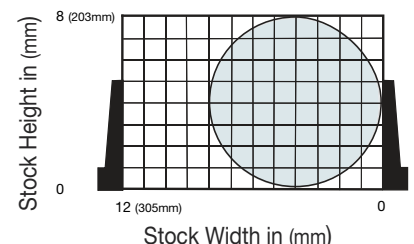

Clousing 12" (305mm) Semi-Automatic Bandsaw

Designed for rugged production use, the Clousing KC12SA bandsaw offers high production output and heavy duty performance in semi-automatic operation.

Features:

- 5 Hp 230/460v 3 ph drive motor
- Semi-automatic operation
- Infinitely variable blade speeds
- LED blade speed readout
- Vise clamps work piece both sides of blade
- Powered hydraulic down feed
- Automatic height setting feature
- Auto shutoff at end of cuts
- Blade breakage/stoppage switch
- 110v control circuit
- Overload protection
- Recirculating coolant system
- (1) general purpose bi-metal blade
- (1) gallon coolant
- Flushing hose for cleanup
- Operator's manual
- Two (2) year limited warranty



Speed control and speed chart on variable speed model KC12SA

Specifications

Model	KC12SA
Motor	5 Hp (3.75 kw), 230/460v 3ph*
Hydraulic Pump Motor	1 Hp (.75 kw)
Hydraulic Oil Capacity	6.5 gallons (25 liters)
Band Wheel Dia.	16" (406mm)
Blade Speeds (Variable Speed)	85-445 fpm (27-135 m/min)
Blade Size	1.25" x .042" x 12'-6" (32 x 1 x 3810mm)
Coolant	Recirculating
Coolant Capacity	10 gallons (39 liters)
90° Cutting Capacity	
Round	12.75" (325mm)
Rectangular	12.75" x 12.6" (325 x 320mm)
	7.9" x 14.2" (200 x 360mm)
**Bundle Cutting Width	6.5" to 10" (165 to 254mm)
**Bundle Cutting Height	2" to 8" (51 to 203mm)
Length	47" (812mm)
Width	75" (1905mm)
Height (head-down)	57" (1449mm)
Height (head-up)	73" (1702mm)
Bed Height	29.5" (660mm)
Net Weight	1,540 lbs. (698 kg)
Shipping Weight	1,760 lbs. (798 kg)

*Other voltages optional.

Design and specifications are subject to change without notice.

Accessories

- CM1201 Chip Conveyor
- VP1201 Variable Vise Pressure System 1 Vise
- SA20 Heavy-duty Roller Table 10' x 15"
- SA21 Heavy-duty Roller Table 5' x 15"
- P10 Stock Stand Assembly 21" - 30"
- CSR1 SAWZIT 1 Gallon
- CSR5 SAWZIT 5 Gallon

Cutting Capacities:

Capacity at 90°

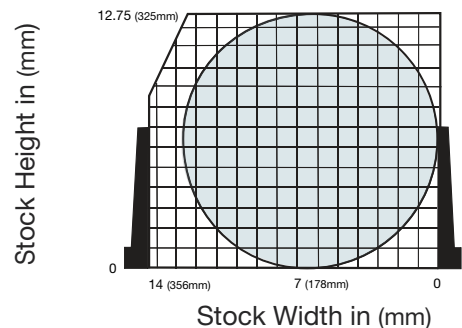



Shown with optional Hydraulic Bundle Clamp and Variable Vise Pressure System

Specifications

Model	KC12AX
Motor	5 Hp (3.75 kw), 230/460v 3ph*
Hydraulic Pump Motor	1 Hp (.75 kw)
Hydraulic Oil Capacity	6.5 gallons (25 liters)
Band Wheel Dia.	16" (406mm)
Blade Speeds (Variable Speed)	95-395 fpm (30-120 m/min)
Blade Size	1.25" x .042" x 12'-6" (32 x 1 x 3810mm)
Coolant	Recirculating
Coolant Capacity	10 gallons (39 liters)
90° Cutting Capacity	
Round	12.75" (300 mm)
Rectangular	12.75" x 12.6" (300 x 320mm) 7.9" x 14.2" (200 x 360mm)
Feed Accuracy	±.004" - .008" (±0.1 - 0.2 mm)
Length of Remnant Manual	.79" (20 mm)
Length of Remnant Automatic	1.97" (50 mm)
Minimum Cut Thickness	.354" (9 mm)
**Bundle Cutting Width	6.5" to 10" (165 to 254mm)
**Bundle Cutting Height	2" to 8" (51 to 203mm)
Feed Length/Index	15.75" (400mm)
Max.Feed (9 times)	141.75" (3600mm)
Length	84" (2133mm)
Width	86" (2184mm)
Height	60" (1524mm)
Height (head-up)	73" (1854mm)
Bed Height	26" (660mm)
Net Weight	3,090 lbs. (1388 kg)
Shipping Weight	3,400 lbs. (1542 kg)

*Other voltages optional. **When machine is equipped with optional hydraulic bundle cutting attachment.

Design and specifications are subject to change without notice.

Clausing 12" (305mm) Automatic Bandsaw

Designed for rugged production use, the Clausing KC12AX bandsaw offers high production output and heavy duty performance in both semi-automatic and fully automatic operation.

A powerful drive motor provides the power, and the optional hydraulic bundling attachment makes multiple cuts easy. The hydraulic shuttle feed system offers up to nine indexes.

Features:

- Full or semi-automatic operation
- Infinitely variable blade speeds
- LED blade speed readout
- Vise clamps work piece both sides of blade
- Hydraulic down feed
- Automatic height setting feature
- Auto shutoff at end of material or after preset number of cuts
- Front-mounted digital length gauge
- Blade breakage/stoppage switch
- 110v control circuit
- Overload protection
- Recirculating coolant system
- Shuttle vise
- (1) General purpose bi-metal blade
- Flushing hose for cleanup
- Operator's manual
- Two (2) year limited warranty

Accessories

- CM1201 Chip Conveyor
- CM1202 Hydraulic Bundle Clamps
- VP1200 Variable Vise Pressure System
- SA20 Heavy-duty Roller Table 10' x 15"
- SA21 Heavy-duty Roller Table 5' x 15"
- P10 Stock Stand Assembly 21" - 30"
- CSR1 SAWZIT 1 Gallon
- CSR5 SAWZIT 5 Gallon

Cutting Capacities:

Capacity at 90°

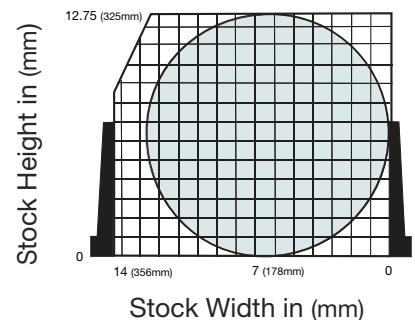

Clausing/Kalamazoo 12" (305mm) Automatic NC Bandsaw

Features:

- Oversized hydraulic cylinder
- Hydraulic shuttle vice assembly
- Inverter controlled infinitely variable speed
- Carbide blade guides with roller bearings
- Two additional guides to support the blade from the top
- Automatic hydraulic blade tensioning
- Power driven blade brushes
- Integral coolant system
- Smart NC-100 technology programmable up to 100 different jobs
- Easy recall and execution of stored parts
- Automatic shutoff after preset number of cuts or when out of stock
- 5.7" HMI touch screen incorporating readout on blade speed, blade life, feed vise position and error code display for self-diagnostics
- Automatic kerf loss compensation & computer controlled multiple indexing
- Precision feed pressure & feed rate
- Bundle/single cutting mode switch
- Automatic height setting feature
- Hydraulic front and rear vises
- Cast iron vises with replaceable hardened wear plates
- Discharge table with built-in coolant return
- Blade slippage or breakage detection
- Adjustable cut-off stock fence
- Additional flushing hose
- Bi-metal saw blade
- Built in work light
- Tool box, leveling pads, and an additional wire brush
- Operation & parts manual
- Two (2) year limited warranty

Accessories

- BT01 Bandsaw Blade Tension Gauge
- CM1201N Chip Conveyor
- CM1202N Hydraulic Bundle Clamps
- VP1200 Variable Vise Pressure System
- SA20 Heavy-duty Roller Table 10' x 15"
- SA21 Heavy-duty Roller Table 5' x 15"
- P10 Stock Stand Assembly 21" - 30"
- CSR1 SAWZIT 1 Gallon
- CSR5 SAWZIT 5 Gallon



Specifications

Model	KC12NC
Motor	5 Hp (3.75 kw), 230/460v 3ph*
Hydraulic Pump Motor	1 Hp (.75 kw)
Hydraulic Oil Capacity	6.6 gallons (25 liters)
Blade Speeds (Variable Speed)	66-330 fpm (20-100m/min)
Blade Size (W x T x L)	1.3"x.042"x150.4" (34x1.1x3820mm)
Blade Tension	Hydraulic
Coolant	Recirculating
Coolant Capacity	11.9 gallons (45 liters)
90° Cutting Capacity	
Round	11.81" (300mm)
Square	11.81" (300mm)
Rectangular	13.4" x 11.81" (340 x 300mm)
Feed Accuracy	±.004" - .008" (±0.1 - 0.2 mm)
Length of Remnant Manual	.79" (20 mm)
Length of Remnant Automatic	1.97" (50 mm)
Minimum Cut Thickness	.354" (9 mm)
**Bundle Cutting Width	7.48" to 11.81" (190 to 300mm)
**Bundle Cutting Height	2.75" to 5.51" (70 to 140mm)
Feed Length/Index	15.86" (403mm)
Max. Feed	255.9" (6500mm)
Length	84" (2133mm)
Width	86" (2184mm)
Height	60" (1524mm)
Height (head-up)	76.7" (1950mm)
Bed Height	26" (660mm)
Net Weight	3,528 lbs. (1600 kg)
Shipping Weight	3,970 lbs. (1800 kg)

*Other voltages optional. **When machine is equipped with optional hydraulic bundle cutting attachment.

Design and specifications are subject to change without notice.



Clausing 13" (330mm) Semi-Automatic Swivel Head Miter Bandsaw Features:

- Advanced hydraulic system provides dependable power for powered clamping and raising the saw head at end of cut
- Full stroke machine vise for tight clamping of any material from operator's panel
- Operator's panel pivots allowing operator to control saw from the rear of machine
- Swivel sawhead allows the operator to accurately pivot head for angle cuts from 0°, for a 90° cut, to 60°
- Carbide blade guides provide excellent stability for the saw blade
- Variable blade speed
- Power chip brush removes chips from the blade extending blade life
- Integrated coolant system
- Cast iron moveable guide arms provide rigidity and stability for an accurate cut
- Flushing hose
- Adjustable work stop
- Tool box with tools
- Manual & parts list
- Two (2) year limited warranty

Available in Manual and Automatic Models

Accessories

- P10 Stock Stand Assembly 21" - 30"
- SA10 Roller Table Assembly 10' x 18"
- SA11 Roller Table Assembly 5' x 18"
- BT01 Bandsaw Blade Tension Gauge
- CSR1 SAWZIT 1 Gallon
- CSR5 SAWZIT 5 Gallon

Cutting Capacities:

Capacity at 90°

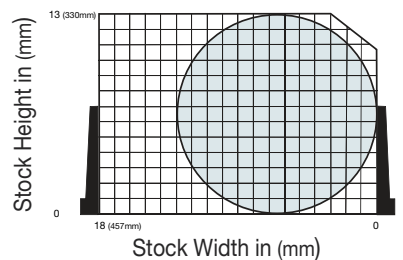

Capacity at 45°

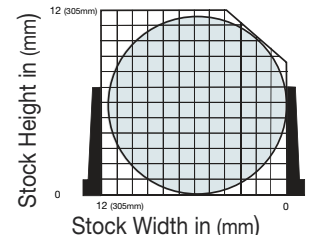

Specifications

Model	MS1318SA
Drive Motor	3 Hp (2.2kw)*
Hydraulic Motor	.25 Hp (.19kw)
Hydraulic Oil Capacity	2 gallons (7.5 liters)
Coolant Motor	.125 Hp (.1kw)
Coolant Capacity	7.8 gallons (7.5 liters)
Blade Speeds (Inf. Variable)	102-377 fpm (31-115 m/min)
Blade Size	1" x .035" x 13'-7" (25 x .9 x 4150mm)
Swivel Angle Range	0° to 60°
Cutting Capacity	
Round @ 90°	13" (330mm)
Round @ 45°	11.5" (292mm)
Round @ 60°	8.7" (220mm)
Square @ 90°	10.6" (270mm)
Square @ 45°	10.5" (268mm)
Square @ 60°	8.7" (221mm)
Rectangular @ 90°	18.5" x 10.6" (470 x 269mm)
Rectangular @ 45°	10.5" x 10.5" (268 x 268mm)
Rectangular @ 60°	8.7" x 8.7" (220 x 220mm)
Bed Height	33" (838mm)
Dimensions:	
Length	75" (1905mm)
Width	34" (863mm)
Height	55.5" (1410mm)
Net Weight	1,400 lbs. (635kg)
Shipping Weight	1,850 lbs. (839kg)

Design and specifications are subject to change without notice.

*Available in 3-phase 230v/460v only

Clausing/Kalamazoo 13" (330mm) Wet Cutting Bandsaw

Features:

- Variable speed drive
- Quick and easy blade installation
- Rotary wire brush for chip removal to help improve blade life
- Enclosed gear box with gears in an oil bath
- Recirculating coolant system
- Gravity fed head controlled by counterbalance springs working with a hydraulic cylinder to insure constant feed pressure on the blade
- Swivel vise enables quick set-up for angle cuts up to 45°
- Two (2) Year Limited Warranty

Accessories

- P10 Stock Stand Assembly 21" - 30"
- SA12 Roller Table Assembly 10' x 18"
- SA13 Roller Table Assembly 5' x 18"
- BT01 Bandsaw Blade Tension Gauge
- CSR1 SAWZIT 1 Gallon
- CSR5 SAWZIT 5 Gallon

Cutting Capacities:

Capacity at 90°

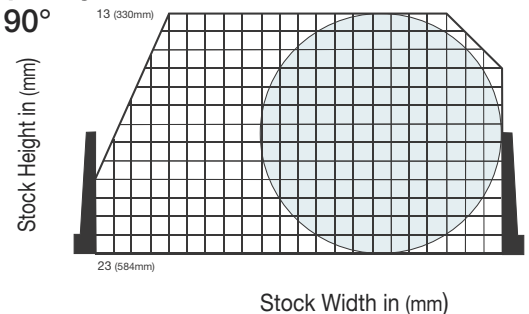

Capacity at 45°

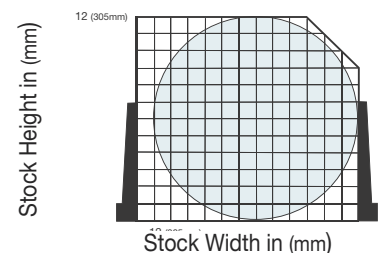

Specifications

Model	13AW
Drive Motor	2 Hp (1.5kw) 115/220v 1 phase or 230/460 3 phase
Band Wheel Dia.	18" (457mm)
Blade Size	1" x .035" x 13'-11" (25 x .9 x 3937mm)
Bed Height	25.5" (648mm)
Vise Opening	23" (584mm)
Blade Speeds	62-390 fpm (20-119 m/min) variable speed
90° Cutting Capacity	
Round	13" (330mm)
Rectangular	10" x 20" (254 x 508mm)
45° Cutting Capacity	
Round	12" (305mm)
Rectangular	9" x 13" (228 x 330mm)
Width	86" (2185mm)
Depth/with stock stop	46"/51.5" (1168/1308)mm)
Height (head-up)	70" (1778mm)
Height (head-down)	38.5" (978mm)
Net Weight	1,100 lbs. (499kg)
Shipping Weight	1,200 lbs. (545kg)

Design and specifications are subject to change without notice.



Clausing/Kalamazoo 12.6" (320mm) Automatic NC Twin Column Bandsaw Features:

- Oversized hydraulic cylinder
- Twin column design ensures rigid support during cutting cycle
- Hydraulic shuttle vice assembly
- Inverter controlled infinitely variable speed
- Carbide blade guides with roller bearings
- Two additional guides to support the blade from the top
- Automatic hydraulic blade tensioning
- Power driven blade brushes
- Integral coolant system
- Smart NC-100 technology programmable up to 100 different jobs
- Easy recall and execution of stored parts
- Automatic shutoff after preset number of cuts or when out of stock
- 5.7" HMI touch screen incorporating readout on blade speed, blade life, feed vise position and error code display for self-diagnostics
- Automatic kerf loss compensation & computer controlled multiple indexing
- Precision feed pressure & feed rate
- Bundle/single cutting mode switch
- Automatic height setting feature
- Hydraulic front and rear vises
- Cast iron vises with replaceable hardened wear plates
- Discharge table with built-in coolant return
- Blade slippage or breakage detection
- Adjustable cut-off stock fence
- Additional flushing hose
- Bi-metal saw blade
- Built in work light
- Tool box, leveling pads, and an additional wire brush
- Operation & parts manual
- Two (2) year limited warranty

Specifications

Model	H1315NC
Motor	5 Hp (3.75 kw), 230/460v 3ph*
Hydraulic Pump Motor	1 Hp (.75 kw)
Hydraulic Oil Capacity	6.6 gallons (25 liters)
Blade Speeds (Variable Speed)	66-330 fpm (20-100 m/min)
Blade Size (W x T x L)	1.3" x .042" x 184" (34 x 1.1 x 4240mm)
Blade Tension	Hydraulic
Coolant	Recirculating
Coolant Capacity	11.9 gallons (45 liters)
90° Cutting Capacity	
Round	12.6" (320mm)
Square	12.6" (320mm)
Rectangular	15" x 12.6" (380 x 320mm)
Feed Accuracy	±.004" - .008" (±0.1 - 0.2 mm)
Length of Remnant Manual	.59" (15 mm)
Length of Remnant Automatic	1.97" (50 mm)
Minimum Cut Thickness	.197" (5 mm)
**Bundle Cutting Width	7.48" to 11.81" (190 to 300mm)
**Bundle Cutting Height	2.75" to 5.51" (70 to 140mm)
Feed Length/Index	15.86" (403mm)
Max. Feed	255.9" (6500mm)
Length	79.13" (2010mm)
Width	78.75" (2000mm)
Height	70.3" (1785mm)
Bed Height	31.1" (790mm)
Net Weight	4,409 lbs. (2000 kg)
Shipping Weight	4,850 lbs. (2200 kg)

Accessories

- BT01 Bandsaw Blade Tension Gauge
- CM1301N Chip Conveyor
- CM1302N Hydraulic Bundle Clamps
- VP1200 Variable Vise Pressure System
- SA20 Heavy-duty Roller Table 10' x 15"
- SA21 Heavy-duty Roller Table 5' x 15"
- P10 Stock Stand Assembly 21" - 30"
- CSR1 SAWZIT 1 Gallon
- CSR5 SAWZIT 5 Gallon

*Other voltages optional.

**When machine is equipped with optional hydraulic bundle cutting attachment.

Design and specifications are subject to change without notice.



Clausing/Kalamazoo 13" (330mm) Automatic NC Swivel Head Miter Bandsaw

Features:

- The swivel sawhead allows cutting at any angle between 90° (straight cut) and 45° (miter cut)
- Precision pivot system facilitates easy and accurate adjustment for angle cuts
- Inverter controlled infinitely variable speed
- Carbide blade guides with roller bearings
- Two additional guides to support the blade from the top
- Automatic hydraulic blade tensioning
- Power driven blade brushes
- Integral coolant system
- Smart NC-100 technology programmable up to 100 different jobs
- Easy recall and execution of stored parts
- Automatic shutoff after preset number of cuts or when out of stock
- 5.7" HMI touch screen incorporating readout on blade speed, blade life, feed vise position and error code display for self-diagnostics
- Automatic kerf loss compensation & computer controlled multiple indexing
- Precision feed pressure & feed rate
- Automatic height setting feature
- Hydraulic front and rear vises
- Cast iron vises with replaceable hardened wear plates
- Computer controlled multiple indexing
- Discharge table with built-in coolant return
- Blade slippage or breakage detection
- Additional flushing hose
- Bi-metal saw blade
- Built in work light
- Tool box, leveling pads, and an additional wire brush
- Operation & parts manual
- Two (2) year limited warranty

Accessories

- BT01 Bandsaw Blade Tension Gauge
- CM1301M Hydraulic Bundle Clamps
- VP1200 Variable Vise Pressure System
- SM1302 Buck Boost Transformer 5 Hp
- SA22 Heavy-duty Roller Table 10' x 19"
- SA23 Heavy-duty Roller Table 5' x 19"
- P10 Stock Stand Assembly 21" - 30"
- CSR1 SAWZIT 1 Gallon
- CSR5 SAWZIT 5 Gallon

Specifications

Model	MS1319NC
Motor	5 Hp (3.75 kw), 230/460v 3ph*
Hydraulic Pump Motor	1 Hp (.75 kw)
Hydraulic Oil Capacity	10.4 gallons (40 liters)
Blade Speeds (Variable Speed)	66-330 fpm (20-100 m/min)
Blade Size (W x T x L)	1.3" x .042" x 184" (34 x 1.1 x 4670mm)
Blade Tension	Hydraulic
Coolant	Recirculating
Coolant Capacity	14.3 gallons (55 liters)
90° Cutting Capacity	
Round	13" (330mm)
Rectangular	11" x 19.68" (280 x 500mm)
45° Cutting Capacity	
Round	11.5" (290mm)
Rectangular	10.43" x 10.43" (265 x 265mm)
Feed Accuracy	±.004" - .008" (±0.1 - 0.2 mm)
Length of Remnant Manual	.275" (70 mm)
Length of Remnant Automatic	9.84" (250 mm)
Minimum Cut Thickness	.126" (3.2 mm)
Feed Length/Index	23.9" (607mm)
Max. Feed	255.9" (6500mm)
Length	114" (2900mm)
Width	102" (2600mm)
Height	86.6" (2200mm)
Bed Height	28.3" (720mm)
Net Weight	3,300 lbs. (1500 kg)
Shipping Weight	3,745 lbs. (1700 kg)

*Other voltages optional.

Design and specifications are subject to change without notice.



Clausing/Kalamazoo 16" (400mm) Automatic Bandsaw

Features:

- Oversized hydraulic cylinder
- Hydraulic shuttle vice assembly
- Inverter controlled infinitely variable speed
- Carbide blade guides with roller bearings
- Two additional guides to support the blade from the top
- Automatic hydraulic blade tensioning
- Power driven blade brushes
- Integral coolant system
- Automatic shutoff at end of material or after preset number of cuts
- Error code display for self-diagnostics
- LCD digital blade speed monitor
- Precision feed pressure & feed rate
- Bundle/single cutting mode switch
- Automatic height setting feature
- Hydraulic front and rear vises
- Cast iron vises with replaceable hardened wear plates
- PLC controlled multiple indexing
- Discharge table with built-in coolant return
- Blade slippage or breakage detection
- Adjustable cut-off stock fence
- Additional flushing hose
- Bi-metal saw blade
- Built in work light
- Tool box, leveling pads, and an additional wire brush
- Operation & parts manual
- Two (2) year limited warranty

Specifications

Model	KC16AX
Motor	7.5 Hp (5.5 kw), 230/460v 3ph*
Hydraulic Pump Motor	2 Hp (1.5 kw)
Hydraulic Oil Capacity	10.6 gallons (40 liters)
Blade Speeds (Variable Speed)	66-330 fpm (20-100 m/min)
Blade Size (W x T x L)	1.6" x .050" x 178" (41 x 1.3 x 4570mm)
Blade Tension	Hydraulic
Coolant	Recirculating
Coolant Capacity	21 gallons (80 liters)
90° Cutting Capacity	
Round	15.75" (400mm)
Square	15.75" (400mm)
Rectangular	15.75" x 15.75" (400 x 400mm)
Feed Accuracy	±.004" - .008" (±0.1 - 0.2 mm)
Length of Remnant Manual	.98" (25 mm)
Length of Remnant Automatic	3.15" (80 mm)
Minimum Cut Thickness	.197" (5 mm)
**Bundle Cutting Width	8.46" to 11.61" (215 to 295mm)
**Bundle Cutting Height	3.94" to 7.45" (100 to 190mm)
Feed Length/Index	23.6" (600mm)
Max. Feed	252.6" (5400mm)
Length	104.4" (2650mm)
Width	94.5" (2400mm)
Height	92.5" (2350mm)
Bed Height	29.5" (750mm)
Net Weight	5,070 lbs. (2300 kg)
Shipping Weight	5,511 lbs. (2500 kg)

*Other voltages optional.

**When machine is equipped with optional hydraulic bundle cutting attachment.

Design and specifications are subject to change without notice.

Accessories

- BT01 Bandsaw Blade Tension Gauge
- CM1601 Chip Conveyor
- CM1602 Hydraulic Bundle Clamps
- VP1200 Variable Vise Pressure System
- SA22 Heavy-duty Roller Table 10' x 19"
- SA23 Heavy-duty Roller Table 5' x 19"
- P10 Stock Stand Assembly 21" - 30"
- CSR1 SAWZIT 1 Gallon
- CSR5 SAWZIT 5 Gallon

Clausing/Kalamazoo 16" (400mm) Automatic NC Bandsaw

Features:

- Oversized hydraulic cylinder
- Hydraulic shuttle vice assembly
- Inverter controlled infinitely variable speed
- Carbide blade guides with roller bearings
- Two additional guides to support the blade from the top
- Automatic hydraulic blade tensioning
- Power driven blade brushes
- Integral coolant system
- Smart NC-100 technology programmable up to 100 different jobs
- Easy recall and execution of stored parts
- Automatic shutoff after preset number of cuts or when out of stock
- 5.7" HMI touch screen incorporating readout on blade speed, blade life, feed vise position and error code display for self-diagnostics
- Automatic kerf loss compensation & computer controlled multiple indexing
- Precision feed pressure & feed rate
- Bundle/single cutting mode switch
- Automatic height setting feature
- Hydraulic front and rear vises
- Cast iron vises with replaceable hardened wear plates
- Discharge table with built-in coolant return
- Blade slippage or breakage detection
- Adjustable material stop
- Additional flushing hose
- Bi-metal saw blade
- Built in work light
- Tool box, leveling pads, and an additional wire brush
- Operation & parts manual
- Two (2) year limited warranty

Accessories

- BT01 Bandsaw Blade Tensionm Gauge
- CM1601N Chip Conveyor
- CM1602N Hydraulic Bundle Clamps
- VP1200 Variable Vise Pressure System
- SA22 Heavy-duty Roller Table 10' x 19"
- SA23 Heavy-duty Roller Table 5' x 19"
- P10 Stock Stand Assembly 21" - 30"
- CSR1 SAWZIT 1 Gallon
- CSR5 SAWZIT 5 Gallon



Specifications

Model	KC16NC
Motor	7.5 Hp (5.5 kw), 230/460v 3ph*
Hydraulic Pump Motor	2 Hp (1.5 kw)
Hydraulic Oil Capacity	10.6 gallons (40 liters)
Blade Speeds (Variable Speed)	66-330 fpm (20-100 m/min)
Blade Size (W x T x L)	1.6" x .05" x 180.4" (41 x 1.3 x 4570mm)
Blade Tension	Hydraulic
Coolant	Recirculating
Coolant Capacity	21 gallons (80 liters)
90° Cutting Capacity	
Round	16" (400mm)
Square	15" (400mm)
Rectangular	16" x 16" (400 x 400mm)
Feed Accuracy	±.004" - .008" (±0.1 - 0.2 mm)
Length of Remnant Manual	.98" (25 mm)
Length of Remnant Automatic	3.15" (80 mm)
Minimum Cut Thickness	.197" (5 mm)
**Bundle Cutting Width	8.46" to 11.61" (215 to 295mm)
**Bundle Cutting Height	3.94" to 7.45" (100 to 190mm)
Feed Length/Index	23.3" (593mm)
Max. Feed	255.9" (6500mm)
Length	96" (2450mm)
Width	71" (2310mm)
Height	97.2" (2470mm)
Bed Height	29.52" (750mm)
Net Weight	5,622 lbs. (2550 kg)
Shipping Weight	6,063 lbs. (2750 kg)

*Other voltages optional.

**When machine is equipped with optional hydraulic bundle cutting attachment.

Design and specifications are subject to change without notice.



Clausing/Kalamazoo 16.5" (420mm) Automatic NC Twin Column Bandsaw

Features:

- Oversized hydraulic cylinder
- Twin column design ensures rigid support during cutting cycle
- Hydraulic shuttle vice assembly
- Inverter controlled infinitely variable speed
- Carbide blade guides with roller bearings
- Two additional guides to support the blade from the top
- Automatic hydraulic blade tensioning
- Power driven blade brushes
- Integral coolant system
- Smart NC-100 technology programmable up to 100 different jobs
- Easy recall and execution of stored parts
- Automatic shutoff after preset number of cuts or when out of stock
- 5.7" HMI touch screen incorporating readout on blade speed, blade life, feed vise position and error code display for self-diagnostics
- Automatic kerf loss compensation & computer controlled multiple indexing
- Precision feed pressure & feed rate
- Bundle/single cutting mode switch
- Automatic height setting feature
- Hydraulic front and rear vises
- Cast iron vises with replaceable hardened wear plates
- Discharge table with built-in coolant return
- Blade slippage or breakage detection
- Adjustable cut-off stock fence
- Additional flushing hose
- Bi-metal saw blade
- Built in work light
- Tool box, leveling pads, and an additional wire brush
- Operation & parts manual
- Two (2) year limited warranty

Specifications

Model	H1616NC
Motor	7.5 Hp (5.6 kw), 230/460v 3ph*
Hydraulic Pump Motor	2 Hp (1.5 kw)
Hydraulic Oil Capacity	10.5 gallons (40 liters)
Blade Speeds (Variable Speed)	66-328 fpm (20-100 m/min)
Blade Size (W x T x L)	1.6" x .05" x 187.8" (41 x 1.3 x 4770mm)
Blade Tension	Hydraulic
Coolant	Recirculating
Coolant Capacity	22.5 gallons (85 liters)
90° Cutting Capacity	
Round	16.5" (420mm)
Square	16.5" (420mm)
Rectangular	16.5" x 16.5" (420 x 420mm)
Feed Accuracy	±.004" - .008" (±0.1 - 0.2 mm)
Length of Remnant Manual	.79" (20 mm)
Length of Remnant Automatic	2.55" (65 mm)
Minimum Cut Thickness	.197" (5 mm)
**Bundle Cutting Width	7.48" to 14.17" (190 to 360mm)
**Bundle Cutting Height	3.94" to 7.08" (100 to 180mm)
Feed Length/Index	19.8" (503mm)
Max. Feed	255.9" (6500mm)
Length	98" (2490mm)
Width	93" (2360mm)
Height	74.4" (1890mm)
Bed Height	27.5" (700mm)
Net Weight	6,614 lbs. (3000 kg)
Shipping Weight	7,275 lbs. (3300 kg)

Accessories

- BT01 Bandsaw Blade Tension Gauge
- CM1601NC Chip Conveyor
- CM1602NC Hydraulic Bundle Clamps
- VP1200 Variable Vise Pressure System
- SA22 Heavy-duty Roller Table 10' x 19"
- SA23 Heavy-duty Roller Table 5' x 19"
- P10 Stock Stand Assembly 21" - 30"
- CSR1 SAWZIT 1 Gallon
- CSR5 SAWZIT 5 Gallon

*Other voltages optional.

**When machine is equipped with optional hydraulic bundle cutting attachment.

Design and specifications are subject to change without notice.

Clausing/Kalamazoo 16" (420mm) Semi- Automatic Bandsaw

Features:

- Twin column design insures rigid support during cutting cycle by keeping the blade parallel and square to the work piece
- Infinitely variable blade speed
- Digital blade speed indicator
- Carbide blade guides with roller bearings
- Two additional guides to support the blade from the top
- Automatic hydraulic blade tensioning
- Power driven blade brushes
- Integral coolant system
- LCD digital blade speed monitor
- Precision feed pressure & feed rate
- Cast iron vises with replaceable hardened wear plates
- Discharge table with built-in coolant return
- Blade slippage or breakage detection
- Additional flushing hose
- Bi-metal saw blade
- Built in work light
- Tool box, leveling pads, and an additional wire brush
- Operation & parts manual
- Two (2) year limited warranty

Accessories

- BT01 Bandsaw Blade Tension Gauge
- CM1601H Chip Conveyor
- VP1201 Variable Vise Pressure System
- SA24 Heavy-duty Roller Table 10' x 21"
- SA25 Heavy-duty Roller Table 5' x 21"
- P10 Stock Stand Assembly 21" - 30"
- CSR1 SAWZIT 1 Gallon
- CSR5 SAWZIT 5 Gallon



Specifications

Model	H1621SA
Motor	7.5 Hp (5.5 kw), 230/460v 3ph*
Hydraulic Pump Motor	2 Hp (1.5 kw)
Hydraulic Oil Capacity	8.75 gallons (35 liters)
Blade Speeds (Variable Speed)	66-328 fpm (20-100 m/min)
Blade Size (W x T x L)	1.6" x .050" x 208.7" (41 x 1.3 x 5300mm)
Blade Tension	Hydraulic
Coolant	Recirculating
Coolant Capacity	23.75 gallons (95 liters)
90° Cutting Capacity	
Round	16.5" (420mm)
Square	16.5" (420mm)
Rectangular	16.5" x 21.6" (420 x 550mm)
Length	43.3" (1100mm)
Width	100.4" (2500mm)
Height	74.8" (1900mm)
Bed Height	27.5" (700mm)
Net Weight	3,960 lbs. (1800 kg)
Shipping Weight	5,060 lbs. (2300 kg)

*Other voltages optional.

Design and specifications are subject to change without notice.



Clausing/Kalamazoo 16.5" (420mm) Semi- Automatic Hydraulic Swivel Head Miter Bandsaw

Features:

- Swivel sawhead mitering from 90° to 60°
- Rigid and heavy-duty pivot and trunion
- Sturdy cast work table
- 24.5" solid discharge table with coolant return
- Variable speeds from 66 thru 330 fpm
- Carbide blade guides with roller bearings
- Two additional bearings to support blade from the top
- Cast iron guide arm supported by heavy-duty cast iron dovetail
- Automatic hydraulic blade tensioning
- Integral coolant system
- Synchronized blade brush
- Precision feed pressure & feed rate dual valve system
- Conveniently designed control station
- Electrical components located inside the control box with main lockout disconnect
- Work height selector
- Industrial rated hydraulic components
- 36" infeed roller table
- Full stroke machine vises
- Breakage detector
- Built-in adjustable material stop
- Adjustable work light
- Additional flushing hose
- Bi-metal saw blade
- Tool box, leveling pads, and an additional wire brush
- Operation & parts manual
- Two (2) year limited warranty

Specifications

Model	MS1625SA
Motor	5 Hp (3.75 kw), 230/460v 3ph*
Hydraulic Pump Motor	1 Hp (.75 kw)
Hydraulic Oil Capacity	11.7 gallons (45 liters)
Blade Speeds (Variable Speed)	66-328 fpm (20-100 m/min)
Blade Size (W x T x L)	1.3" x .042" x 209" (34 x 1.1 x 5300mm)
Blade Tension	Hydraulic
Coolant	Recirculating
Coolant Capacity	15.6 gallons (60 liters)
90° Cutting Capacity	
Round	16.5" (420mm)
Rectangular	15" x 26.6" (380 x 650mm)
45° Cutting Capacity	
Round	16" (400mm)
Rectangular	16" x 16" (400 x 400mm)
60° Cutting Capacity	
Round	10" (250mm)
Rectangular	16" x 10" (400 x 250mm)
Length	90.6" (2300mm)
Width	114" (2900mm)
Height	98.4" (2500mm)
Bed Height	29.5" (750mm)
Net Weight	2,640 lbs. (1200 kg)
Shipping Weight	3,300 lbs. (1500 kg)

*Other voltages optional.

Design and specifications are subject to change without notice.

Accessories

- BT01 Bandsaw Blade Tension Gauge
- CM1601M Chip Conveyor
- VP1201 Variable Vise Pressure System
- SA26 Heavy-duty Roller Table 10' x 25"
- SA27 Heavy-duty Roller Table 5' x 25"
- P10 Stock Stand Assembly 21" - 30"
- CSR1 SAWZIT 1 Gallon
- CSR5 SAWZIT 5 Gallon

Clausing/Kalamazoo 16" (420mm) Semi- Automatic Bandsaw

Features:

- Twin column design insures rigid support during cutting cycle by keeping the blade parallel and square to the work piece
- Infinitely variable blade speed
- Digital blade speed indicator
- Carbide blade guides with roller bearings
- Two additional guides to support the blade from the top
- Automatic hydraulic blade tensioning
- Power driven blade brushes
- Integral coolant system
- Automatic shut-off at end of cut
- Precision feed pressure & feed rate
- Cast iron vises with replaceable hardened wear plates
- Discharge table with built-in coolant return
- Blade slippage or breakage detection
- Additional flushing hose
- Bi-metal saw blade
- Built in work light
- Tool box, leveling pads, and an additional wire brush
- Operation & parts manual
- Two (2) year limited warranty

Accessories

- BT01 Bandsaw Blade Tension Gauge
- CM1601HA Chip Conveyor
- VP1200 Variable Vise Pressure System
- SA26 Heavy-duty Roller Table 10' x 25"
- SA27 Heavy-duty Roller Table 5' x 25"
- SM1303 Buck Boost Transformer 7.5 Hp
- P10 Stock Stand Assembly 21" - 30"
- CSR1 SAWZIT 1 Gallon
- CSR5 SAWZIT 5 Gallon



Specifications

Model	H1628SA
Motor	7.5 Hp (5.5 kw), 230/460v 3ph*
Hydraulic Pump Motor	1 Hp (.75 kw)
Hydraulic Oil Capacity	13 gallons (50 liters)
Blade Speeds (Variable Speed)	66-328 fpm (20-100 m/min)
Blade Size (W x T x L)	1.6" x .05" x 215" (41 x 1.3 x 5450mm)
Blade Tension	Hydraulic
Coolant	Recirculating
Coolant Capacity	10.4 gallons (40 liters)
90° Cutting Capacity	
Round	16.5" (420mm)
Square	16.5" (420mm)
Rectangular	13.8" x 27.5" (350 x 700mm)
Length	47" (1200mm)
Width	108" (2750mm)
Height	84.2" (2150mm)
Bed Height	27.5" (700mm)
Net Weight	4,250 lbs. (1930 kg)
Shipping Weight	5,940 lbs. (2700 kg)

*Other voltages optional.

Design and specifications are subject to change without notice.

Clausing/Kalamazoo 18" (460mm) Automatic Bandsaw

Features:

- Oversized hydraulic cylinder
- Hydraulic shuttle vice assembly
- Inverter controlled infinitely variable speed
- Carbide blade guides with roller bearings
- Two additional guides to support the blade from the top
- Automatic hydraulic blade tensioning
- Power driven blade brushes
- Integral coolant system
- Automatic shutoff at end of material or after preset number of cuts
- LCD digital blade speed monitor
- Precision feed pressure & feed rate
- Bundle/single cutting mode switch
- Automatic height setting feature
- Hydraulic front and rear vises
- Cast iron vises with replaceable hardened wear plates
- PLC controlled multiple indexing
- Discharge table with built-in coolant return
- Blade slippage or breakage detection
- Adjustable cut-off stock fence
- Additional flushing hose
- Bi-metal saw blade
- Built in work light
- Tool box, leveling pads, and an additional wire brush
- Operation & parts manual
- Two (2) year limited warranty

Specifications

Model	KC18AX
Motor	7.5 Hp (5.5 kw), 230/460v 3ph*
Hydraulic Pump Motor	2 Hp (1.5 kw)
Hydraulic Oil Capacity	10.6 gallons (40 liters)
Blade Speeds (Variable Speed)	66-330 fpm (20-100 m/min)
Blade Size (W x T x L)	1.6" x .050" x 184" (41 x 1.3 x 4670mm)
Blade Tension	Hydraulic
Coolant	Recirculating
Coolant Capacity	21 gallons (80 liters)
90° Cutting Capacity	
Round	18" (460mm)
Square	18" (460mm)
Rectangular	18" x 18" (460 x 460mm)
Feed Accuracy	±.004" - .008" (±0.1 - 0.2 mm)
Length of Remnant Manual	.79" (20 mm)
Length of Remnant Automatic	2.95--" (75 mm)
Minimum Cut Thickness	.197" (5 mm)
Feed Length/Index	23.6" (600mm)
Max. Feed	252.6" (5400mm)
Length	104.4" (2650mm)
Width	94.5" (2400mm)
Height (head-down)	92.5" (2350mm)
Height (head-up)	76" (1930mm)
Bed Height	29.5" (750vmm)
Net Weight	6,160 lbs. (2800 kg)
Shipping Weight	6,600 lbs. (3000 kg)

*Other voltages optional.

Design and specifications are subject to change without notice.

Accessories

- BT01 Bandsaw Blade Tension Gauge
- CM1801 Chip Conveyor
- CM1802 Hydraulic Bundle Clamps
- VP1200 Variable Vise Pressure System
- SA22 Heavy-duty Roller Table 10' x 19"
- SA23 Heavy-duty Roller Table 5' x 19"
- P10 Stock Stand Assembly 21" - 30"
- CSR1 SAWZIT 1 Gallon
- CSR5 SAWZIT 5 Gallon



Clausing/Kalamazoo 19.7" (500mm) Semi- Automatic Hydraulic Swivel Head Miter Bandsaw

Features:

- Swivel sawhead mitering from 90° to 60°
- Rigid, oversized round columns precision ground to ensure smooth and consistent feed rate
- 7.5 degree blade cant for longer blade life
- 45 degree backward swivel with automatic angle lock-in
- Specially designed gearbox for smooth and powerful cutting
- Heavy duty inverter blade drive system
- Carbide blade guides
- Two additional guide bearings for extra support of the blade
- Automatic hydraulic blade tensioning device
- Integral coolant system
- Synchronized power driven blade brush
- Independent control station
- Infinitely variable blade speed control
- Precision feed pressure & feed rate dual valve system
- "Last cut" or "keep on" selector switch
- Work height selector
- Extremely heavy-duty cast iron machines vises ensuring tight clamping
- 2 sets of full stroke cylinder vises
- Shadow light projection for precise length measurement
- Proximity switch for sensing blade slippage or breakage
- Electrical and hydraulic safety interlock
- Conduits protection measure
- "Alert Orange" safety measure
- Blade "clip" device for easy blade change
- Bi-metal saw blade
- Tool box, leveling pads, and an additional wire brush
- Operation & parts manual
- Two (2) year limited warranty

Accessories

- BT01 Bandsaw Blade Tension Gauge
- CM1901M Hydraulic Chip Conveyor
- VP1201 Variable Vise Pressure System
- SA26 Heavy-duty Roller Table 10' x 25"
- SA27 Heavy-duty Roller Table 5' x 25"
- SM1303 Buck Boost Transformer 7.5 Hp
- P10 Stock Stand Assembly 21" - 30"
- CSR1 SAWZIT 1 Gallon
- CSR5 SAWZIT 5 Gallon

Specifications

Model	MS1927SA
Motor	7.5 Hp (5.6 kw), 230/460v 3ph*
Hydraulic Pump Motor	1 Hp (.75 kw)
Hydraulic Oil Capacity	9.1 gallons (35 liters)
Blade Speeds (Variable Speed)	82-312 fpm (25-95 m/min)
Blade Size (W x T x L)	1.6" x .050" x 283" (41 x 1.3 x 5450mm)
Blade Tension	Hydraulic
Coolant	Recirculating
Coolant Capacity	13 gallons (50 liters)
90° Cutting Capacity	
Round	19.7" (500mm)
Rectangular	15.7" x 27.6" (400 x 700mm)
45° Cutting Capacity	
Round	13.8" (350mm)
Rectangular	18.5" x 13.8" (470 x 350mm)
60° Cutting Capacity	
Round	7.9" (200mm)
Rectangular	19.7" x 7.9" (500 x 200mm)
Length	69" (1750mm)
Width	113.5" (2880mm)
Height	89" (2260mm)
Bed Height	27.5" (700mm)
Net Weight	6,600 lbs. (3000 kg)
Shipping Weight	7,480 lbs. (3400 kg)

*Other voltages optional.

Design and specifications are subject to change without notice.



Clausing/Kalamazoo 20.5" (520mm) Automatic NC Twin Column Bandsaw

Features:

- Oversized hydraulic cylinder
- Hydraulic shuttle vice assembly
- Inverter controlled infinitely variable speed
- Carbide blade guides with roller bearings
- Two additional guides to support the blade from the top
- Automatic hydraulic blade tensioning
- Power driven blade brushes
- Integral coolant system
- Smart NC-100 technology programmable up to 100 different jobs
- Easy recall and execution of stored parts
- Automatic shutoff after preset number of cuts or when out of stock
- 5.7" HMI touch screen incorporating readout on blade speed, blade life, feed vise position and error code display for self-diagnostics
- Automatic kerf loss compensation & computer controlled multiple indexing
- Precision feed pressure & feed rate
- Bundle/single cutting mode switch
- Automatic height setting feature
- Hydraulic front and rear vises
- Cast iron vises with replaceable hardened wear plates
- Discharge table with built-in coolant return
- Blade slippage or breakage detection
- Adjustable cut-off stock fence
- Additional flushing hose
- Bi-metal saw blade
- Built in work light
- Tool box, leveling pads, and an additional wire brush
- Operation & parts manual
- Two (2) year limited warranty

Specifications

Model	H2022NC
Motor	7.5 Hp (5.6 kw), 230/460v 3ph*
Hydraulic Pump Motor	2 Hp (1.5 kw)
Hydraulic Oil Capacity	10.5 gallons (40 liters)
Blade Speeds (Variable Speed)	66-328 fpm (20-100 m/min)
Blade Size (W x T x L)	2.1" x .06" x 238" (54 x 1.6 x 6040mm)
Blade Tension	Hydraulic
Coolant	Recirculating
Coolant Capacity	22.5 gallons (85 liters)
90° Cutting Capacity	
Round	20.5" (520mm)
Square	20.5" (520mm)
Rectangular	22" x 20.5" (560mm x 520mm)
Feed Accuracy	±.004" - .008" (±0.1 - 0.2 mm)
Length of Remnant Manual	.79" (20 mm)
Length of Remnant Automatic	3.93" (100 mm)
Minimum Cut Thickness	.394" (10 mm)
**Bundle Cutting Width	9.84" to 18.5" (250 to 470mm)
**Bundle Cutting Height	5.9" to 12.4" (150 to 315mm)
Feed Length/Index	23.6" (600mm)
Max. Feed	255.9" (6500mm)
Length	114.2" (2900mm)
Width	114.2" (2100mm)
Height	82.7" (2055mm)
Bed Height	27.2" (690mm)
Net Weight	8,157 lbs. (3700 kg)
Shipping Weight	9,480 lbs. (4300 kg)

Accessories

- BT01 Bandsaw Blade Tension Gauge
- CM2001N Chip Conveyor
- CM2002N Hydraulic Bundle Clamps
- VP1200 Variable Vise Pressure System
- SA26 Heavy-duty Roller Table 10' x 25"
- SA27 Heavy-duty Roller Table 5' x 25"
- P10 Stock Stand Assembly 21" - 30"
- CSR1 SAWZIT 1 Gallon
- CSR5 SAWZIT 5 Gallon

*Other voltages optional.

**When machine is equipped with optional hydraulic bundle cutting attachment.

Design and specifications are subject to change without notice.



Clausing/Kalamazoo 20" (500mm) Semi- Automatic Bandsaw

Features:

- Twin column design insures rigid support during cutting cycle by keeping the blade parallel and square to the work piece
- Infinitely variable blade speed
- Digital blade speed indicator
- Carbide blade guides with roller bearings
- Two additional guides to support the blade from the top
- Automatic hydraulic blade tensioning
- Power driven blade brushes
- Integral coolant system
- Automatic shutoff at end of cut
- LCD digital blade speed monitor
- Precision feed pressure & feed rate
- Cast iron vises with replaceable hardened wear plates
- Discharge table with built-in coolant return
- Blade slippage or breakage detection
- Additional flushing hose
- Bi-metal saw blade
- Built in work light
- Tool box, leveling pads, and an additional wire brush
- Operation & parts manual
- Two (2) year limited warranty

Specifications

Model	H2030SA
Motor	7.5 Hp (5.5 kw), 230/460v 3ph*
Hydraulic Pump Motor	2 Hp (.75 kw)
Hydraulic Oil Capacity	10 gallons (40 liters)
Blade Speeds (Variable Speed)	66-328 fpm (20-100 m/min)
Blade Size (W x T x L)	2" x .063" x 238" (54 x 1.6 x 6040mm)
Blade Tension	Hydraulic
Coolant	Recirculating
Coolant Capacity	21.5 gallons (85 liters)
90° Cutting Capacity	
Round	20" (500mm)
Square	20" (500mm)
Rectangular	20" x 29.5" (500 x 750mm)
Length	55.5" (1410mm)
Width	124" (3150mm)
Height	79" (2010mm)
Bed Height	27.5" (700mm)
Net Weight	4,620 lbs. (2100 kg)
Shipping Weight	5,720 lbs. (2600 kg)

*Other voltages optional.

Design and specifications are subject to change without notice.

Accessories

- BT01 Bandsaw Blade Tension Gauge
- CM2001H Chip Conveyor
- VP1201 Variable Vise Pressure System
- SA26 Heavy-duty Roller Table 10' x 25"
- SA27 Heavy-duty Roller Table 5' x 25"
- P10 Stock Stand Assembly 21" - 30"
- CSR1 SAWZIT 1 Gallon
- CSR5 SAWZIT 5 Gallon



Clausing/Kalamazoo 22" (560) Automatic NC Twin Column Bandsaw

Features:

- Oversized hydraulic cylinder
- Twin column design ensures rigid support during cutting cycle
- Hydraulic shuttle vice assembly
- Inverter controlled infinitely variable speed
- Carbide blade guides with roller bearings
- Two additional guides to support the blade from the top
- Automatic hydraulic blade tensioning
- Power driven blade brushes
- Integral coolant system
- Smart NC-100 technology programmable up to 100 different jobs
- Easy recall and execution of stored parts
- Automatic shutoff after preset number of cuts or when out of stock
- 5.7" HMI touch screen incorporating readout on blade speed, blade life, feed vise position and error code display for self-diagnostics
- Automatic kerf loss compensation & computer controlled multiple indexing
- Precision feed pressure & feed rate
- Bundle/single cutting mode switch
- Automatic height setting feature
- Hydraulic front and rear vises
- Cast iron vises with replaceable hardened wear plates
- Discharge table with built-in coolant return
- Blade slippage or breakage detection
- Adjustable cut-off stock fence
- Additional flushing hose
- Bi-metal saw blade
- Built in work light
- Tool box, leveling pads, and an additional wire brush
- Operation & parts manual
- Two (2) year limited warranty

Specifications

Model	H2230NC
Motor	10 Hp (7.5 kw), 230/460v 3ph*
Hydraulic Pump Motor	2 Hp (1.5 kw)
Hydraulic Oil Capacity	13 gallons (50 liters)
Blade Speeds (Variable Speed)	66-328 fpm (20-100 m/min)
Blade Size (W x T x L)	2.1" x .06" x 262" (54 x 1.6 x 6665mm)
Blade Tension	Hydraulic
Coolant	Recirculating
Coolant Capacity	22.5 gallons (85 liters)
90° Cutting Capacity	
Round	22" (560mm)
Square	22" (560mm)
Rectangular	30" x 22" (760mm x 560mm)
Feed Accuracy	±.004" - .008" (±0.1 - 0.2 mm)
Length of Remnant Manual	.79" (20 mm)
Length of Remnant Automatic	6.49" (165mm)
Minimum Cut Thickness	.551" (14 mm)
**Bundle Cutting Width	9.84" to 18.5" (250 to 470mm)
**Bundle Cutting Height	6.73" to 10.16" (265 to 400mm)
Feed Length/Index	19.8" (503mm)
Max. Feed	255.9" (6500mm)
Length	92" (2330mm)
Width	153.2" (3890mm)
Height	93.9" (2385mm)
Bed Height	27.2" (690mm)
Net Weight	13,228 lbs. (6000 kg)
Shipping Weight	14,550 lbs. (6600 kg)

*Other voltages optional.

**When machine is equipped with optional hydraulic bundle cutting attachment.

Design and specifications are subject to change without notice.

Accessories

- BT01 Bandsaw Blade Tension Gauge
- CM2201N Chip Conveyor
- CM2202N Hydraulic Bundle Clamps
- VP1200 Variable Vise Pressure System
- SA26 Heavy-duty Roller Table 10' x 25"
- SA27 Heavy-duty Roller Table 5' x 25"
- P10 Stock Stand Assembly 21" - 30"
- CSR1 SAWZIT 1 Gallon
- CSR5 SAWZIT 5 Gallon

Clausing/Kalamazoo 24" (620mm) Semi- Automatic Bandsaw

Features:

- Oversized precision ground, large dual columns
- Cross link connecting two columns for enhanced structural strength
- Specially designed gearbox for high lateral pressure
- Heavy-duty inverter blade drive system
- LED speed indicator
- Cam lock carbide blade guides with bearing guides
- Two additional guides to support the blade from the top
- Automatic hydraulic blade tensioning device
- Integral coolant system
- Synchronized power driven blade brush
- PLC control
- Ergonomically located independent control station
- Precision feed pressure & feed rate dual valve system
- Work height selector & air gap eliminator
- "Shut off" or "keep on" selector
- Split vise jaws
- Full stroke ductile cast iron split vise
- Hydraulically powered in-feed lift roller for forward and backward feeding
- Ductile cast iron vises with replaceable hardened wear plates
- Proximity switch for sensing blade slippage or breakage
- Blade "clip" device for easy blade change
- Discharge roller workbed with built-in coolant return
- Additional flushing hose
- Bi-metal saw blade
- Tool box, leveling pads, and an additional wire brush
- Operation & parts manual
- Two (2) year limited warranty

Accessories

- BT01 Bandsaw Blade Tension Gauge
- CM2401H Chip Conveyor
- VP1201 Variable Vise Pressure System
- SA26 Heavy-duty Roller Table 10' x 25"
- SA27 Heavy-duty Roller Table 5' x 25"
- P10 Stock Stand Assembly 21" - 30"
- CSR1 SAWZIT 1 Gallon
- CSR5 SAWZIT 5 Gallon



Specifications

Model	H2430SA
Motor	10 Hp (7.3 kw), 230/460v 3ph*
Hydraulic Pump Motor	2 Hp (1.5 kw)
Hydraulic Oil Capacity	12.5 gallons (50 liters)
Blade Speeds (Variable Speed)	66-328 fpm (20-100 m/min)
Blade Size (W x T x L)	2.1" x .063" x 283" (54 x 1.6 x 7200mm)
Blade Tension	Hydraulic
Coolant	Recirculating
Coolant Capacity	25 gallons (100 liters)
90° Cutting Capacity	
Round	24.4" (620mm)
Square	24.4" (620mm)
Rectangular	24.4" x 30" (620 x 760mm)
Length	47.2" (1200mm)
Width	140" (3560mm)
Height	93" (2360mm)
Bed Height	23.6" (700mm)
Net Weight	7,700 lbs. (3500 kg)
Shipping Weight	8,580 lbs. (3900 kg)

*Other voltages optional.

Design and specifications are subject to change without notice.

Clausing/Kalamazoo 26" (660mm) Semi- Automatic Hydraulic Swivel Head Miter Bandsaw

Features:

- Swivel sawhead mitering from 90° to 60°
- Precision ground, oversized round column design
- 7.5 degree blade cant for longer blade life
- Heavy duty, rigid saw frame supported by two large bore hydraulic cylinders
- Cross link connecting the two columns for enhanced structural strength
- 45 degree forward & backward swivel with automatic angle lock-in smooth and powerful cutting
- Heavy-duty inverter blade drive system
- Easy-to-read LED speed indicator
- Hydraulically operated carbide blade guides
- Two additional guide bearings for extra support of the blade
- Automatic hydraulic blade tensioning device
- Hydraulically actuated guide arm
- Integral coolant system
- Synchronized power driven blade brush
- Independent control station
- Precision feed pressure & feed rate dual valve system
- "Shut off" or "keep on" selector switch
- Vise pressure detector
- Hydraulically powered material infeed lift roller
- Idle roller work table for material feeding
- Light projection for precise length measurement
- Two full stroke cylinder vises
- Proximity switch for sensing blade slippage or breakage
- Electrical and hydraulic safety interlock
- Conduits protection
- Bi-metal saw blade
- Tool box, leveling pads, and an additional wire brush
- Operation & parts manual
- Two (2) year limited warranty

Accessories

- BT01 Bandsaw Blade Tension Gauge
- CM2601M Chip Conveyor
- VP1201 Variable Vise Pressure System
- P10 Stock Stand Assembly 21" - 30"
- CSR1 SAWZIT 1 Gallon
- CSR5 SAWZIT 5 Gallon



Specifications

Model	MS2640SA
Motor	10 Hp (7.5 kw), 230/460v 3ph*
Hydraulic Pump Motor	3 Hp (2.25 kw)
Hydraulic Oil Capacity	15.6 gallons (60 liters)
Blade Speeds (Variable Speed)	49-295 fpm (15-90 m/min)
Blade Size (W x T x L)	2.1" x .063" x 326.8" (54 x 1.6 x 8300mm)
Blade Tension	Hydraulic
Coolant	Recirculating
Coolant Capacity	26 gallons (100 liters)
90° Cutting Capacity	
Round	26" (660mm)
Rectangular	20.5" x 40" (520 x 1020mm)
45° Cutting Capacity	
Round	23" (620mm)
Rectangular	20.5" x 24.4" (520 x 620mm)
60° Cutting Capacity	
Round	15.7" (400mm)
Rectangular	21.3" x 15.7" (540 x 400mm)
Length	148" (3750mm)
Width	154" (3900mm)
Height	109" (2765mm)
Bed Height	31.9" (810mm)
Net Weight	9,460 lbs. (4300 kg)
Shipping Weight	12,254 lbs. (5570 kg)

*Other voltages optional.

Design and specifications are subject to change without notice.



Clausing/Kalamazoo 31.6" (800mm) Semi- Automatic Bandsaw

Features:

- The extra heavy-duty saw frame is supported by two large bore hydraulic cylinders, providing unsurpassed rigidity, and the smoothest cutting possible
- Dual Column design with precision ground columns ensures smooth saw frame movement and consistent cutting force throughout the cutting cycle
- Large diameter cast iron bandwheels
- Inverter drive with infinitely variable blade speeds with blade speed indicator
- Hydraulic controlled tungsten carbide blade guide
- Groove shaped designed blade guides
- Hydraulic controlled blade tension device
- Hydraulic driven guide arm
- Proximity switch for sensing blade slippage or breakage
- Independent wire brush drive system
- 'Auto shut off' function automatically stops the machine and shuts down the hydraulic system at the end of the last cut
- Two full stroke cylinder vices
- Discharge table with built-in coolant return
- Heavy-duty machine structure design for heavy cutting jobs
- Precise flow control valve to finely adjust the cutting speed
- Additional flushing hose
- Bi-metal saw blade
- Tool box, leveling pads, and an additional wire brush
- Operation & parts manual
- Two (2) year limited warranty

Specifications

Model	H3140SA
Motor	15 Hp (11.2 kw), 230/460v 3ph*
Hydraulic Pump Motor	3 Hp (2.2 kw)
Hydraulic Oil Capacity	26 gallons (100 liters)
Blade Speeds (Variable Speed)	49-264 fpm (15-80 m/min)
Blade Size (W x T x L)	2.6" x .063" x 346.5" (67 x 1.6 x 8800mm)
Blade Tension	Hydraulic
Coolant	Recirculating
Coolant Capacity	32 gallons (120 liters)
90° Cutting Capacity	
Round	31.5" (800mm)
Square	31.5" (800mm)
Rectangular	31.5" x 39.4" (800 x 1000mm)
Length	90" (2286mm)
Width	169" (4293mm)
Height	105" (2667mm)
Bed Height	25.2" (640mm)
Net Weight	22,000 lbs. (10000 kg)
Shipping Weight	23,320 lbs. (10578 kg)

*Other voltages optional.

Design and specifications are subject to change without notice.

Accessories

- BT01 Bandsaw Blade Tension Gauge
- CM3101H Chip Conveyor
- VP1201 Variable Vise Pressure System
- P10 Stock Stand Assembly 21" - 30"
- CSR1 SAWZIT 1 Gallon
- CSR5 SAWZIT 5 Gallon

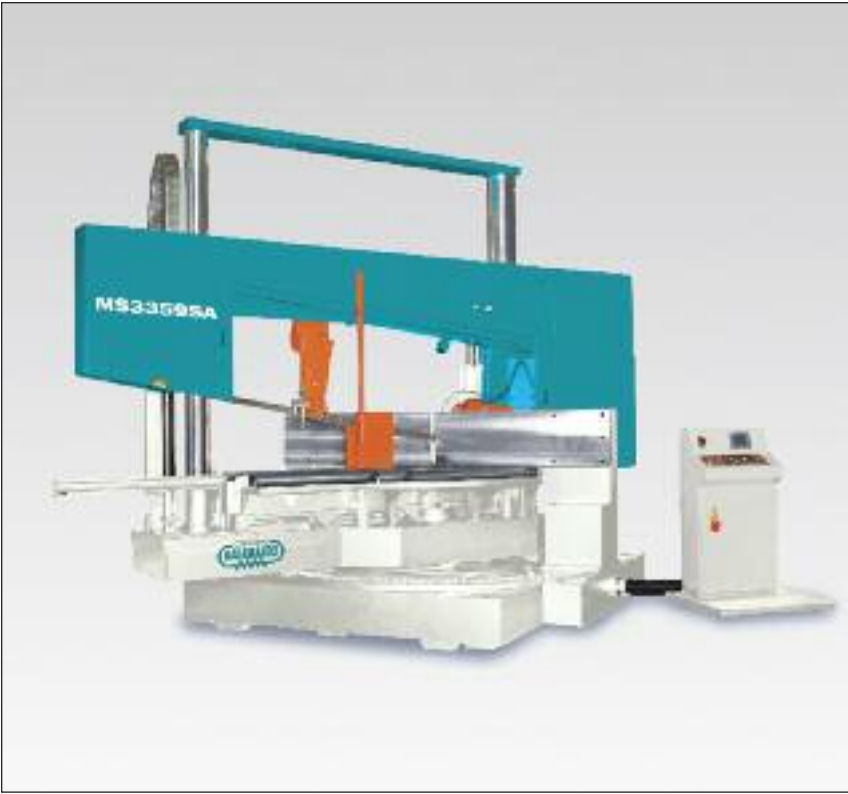

Clausing/Kalamazoo 33.5" (850mm) Semi- Automatic Hydraulic Swivel Head Miter Bandsaw

Features:

- Swivel sawhead mitering from 90° to 60°
- Precision ground, oversized round column design
- 10 degree blade cant for longer blade life
- Heavy-duty, rigid saw frame supported by two large bore hydraulic cylinders
- Cross link connecting the two columns for enhanced structural strength
- 45 degree forward & backward swivel with automatic angle lock-in smooth and powerful cutting
- Heavy-duty inverter blade drive system
- Easy-to-read LED speed indicator
- Hydraulically operated carbide blade guides
- Two additional guide bearings for extra support of the blade
- Automatic hydraulic blade tensioning device
- Hydraulically actuated guide arm
- Integral coolant system
- Synchronized power driven blade brush
- Independent control station
- Precision feed pressure & feed rate dual valve system
- "Shut off" or "keep on" selector switch
- Vise pressure detector
- Hydraulically powered material infeed lift roller
- Idle roller work table for material feeding
- Light projection for precise length measurement
- Two full stroke cylinder vises
- Proximity switch for sensing blade slippage or breakage
- Electrical and hydraulic safety interlock
- Conduits protection
- Bi-metal saw blade
- Tool box, leveling pads, and an additional wire brush
- Operation & parts manual
- Two (2) year limited warranty

Accessories

- BT01 Bandsaw Blade Tension Gauge
- CM3301M Chip Conveyor
- VP1201 Variable Vise Pressure System
- P10 Stock Stand Assembly 21" - 30"
- CSR1 SAWZIT 1 Gallon
- CSR5 SAWZIT 5 Gallon

Specifications

Model	MS3359SA
Motor	15 Hp (11.25 kw), 230/460v 3ph*
Hydraulic Pump Motor	3 Hp (2.25 kw)
Hydraulic Oil Capacity	20.8 gallons (80 liters)
Blade Speeds (Variable Speed)	66-330 fpm (20-100 m/min)
Blade Size (W x T x L)	2.6" x .063" x 468" (67 x 1.6 x 11880mm)
Blade Tension	Hydraulic
Coolant	Recirculating
Coolant Capacity	39 gallons (150 liters)
90° Cutting Capacity	
Round	33.5" (850mm)
Rectangular	29.5" x 59" (750 x 1500mm)
45° Cutting Capacity	
Round	31.5" (800mm)
Rectangular	29.5" x 35.4" (750 x 900mm)
60° Cutting Capacity	
Round	22.8" (580mm)
Rectangular	29.5" x 22.8" (750 x 580mm)
Length	203" (5160mm)
Width	219" (5550mm)
Height	165" (4200mm)
Bed Height	51" (1295mm)
Net Weight	39,600 lbs. (18000 kg)
Shipping Weight	46,200 lbs. (21000 kg)

*Other voltages optional.

Design and specifications are subject to change without notice.



Clausing/Kalamazoo 43.3" (1100mm) Semi- Automatic Bandsaw

Features:

- The extra heavy-duty saw frame is supported by two large bore hydraulic cylinders, providing unsurpassed rigidity, and the smoothest cutting possible
- Dual Column design with precision ground columns ensures smooth saw frame movement and consistent cutting force throughout the cutting cycle
- Specially designed planetary gear reducer for optimum mechanical efficiency
- Inverter controlled infinitely variable blade speed with blade speed indicator
- Independent wire brush system
- Hydraulically powered guide arm is positioned from the control panel
- Hydraulic Blade Tension System, with easy to read pressure gauge
- Carbide blade guides are activated hydraulically
- Additional blade guiding bearings for extra support
- Heavy cast iron moveable Guide Arm is hydraulically powered from the control panel
- Auto shut off function
- User-friendly control panel
- Precision Feed Pressure control valve with micro-precision adjustment
- Saw Blade Height Selector
- Hydraulic driven work bed with rollers for moving large material safely
- Three sets of vises design. The front and middle vises hold the stock during cutting while the guide vise can be separately controlled to guide the material during feeding cycle
- Stock position cylinder pushes stock away from fixed vise for easy material handling
- Shadow light for material measurement
- Blade breakage and/or slippage detector
- Bi-metal saw blade
- Tool box, leveling pads, and an additional wire brush
- Vibration damper
- Operation & parts manual
- Two (2) year limited warranty

Specifications

Model	H4351SA
Motor	15 Hp (11.2 kw), 230/460v 3ph*
Hydraulic Pump Motor	3 Hp (2.2 kw)
Hydraulic Oil Capacity	35 gallons (160 liters)
Blade Speeds (Variable Speed)	49-264 fpm (15-80 m/min)
Blade Size (W x T x L)	3.1" x .063" x 433" (80 x 1.6 x 11000mm)
Blade Tension	Hydraulic
Coolant	Recirculating
Coolant Capacity	44 gallons (200 liters)
90° Cutting Capacity	
Round	43.3" (1100mm)
Square	43.3" (1100mm)
Rectangular	43.3" x 51.2" (1100 x 1300mm)
Length	86.6" (2200mm)
Width	193" (4900mm)
Height	137.8" (3500mm)
Bed Height	24.4" (620mm)
Net Weight	30,140 lbs. (13700 kg)
Shipping Weight	33,455 lbs. (15175 kg)

*Other voltages optional.

Design and specifications are subject to change without notice.

Accessories

- BT01 Bandsaw Blade Tension Gauge
- CM4301H Chip Conveyor
- VP1201 Variable Vise Pressure System
- P10 Stock Stand Assembly 21" - 30"
- CSR1 SAWZIT 1 Gallon
- CSR5 SAWZIT 5 Gallon

Clausing/Kalamazoo 51" (1300mm) Semi- Automatic Bandsaw

Features:

- The extra heavy-duty saw frame is supported by two large bore hydraulic cylinders, providing unsurpassed rigidity, and the smoothest cutting possible
- Dual Column design with precision ground columns ensures smooth saw frame movement and consistent cutting force throughout the cutting cycle
- Specially designed planetary gear reducer for optimum mechanical efficiency
- Inverter controlled infinitely variable blade speed with blade speed indicator
- Independent wire brush system
- Hydraulically powered guide arm is positioned from the control panel
- Hydraulic Blade Tension System, with easy to read pressure gauge
- Carbide blade guides are activated hydraulically
- Additional blade guiding bearings for extra support
- Heavy cast iron moveable Guide Arm is hydraulically powered from the control panel
- Auto shut off function
- User-friendly control panel
- Precision Feed Pressure control valve with micro-precision adjustment
- Saw Blade Height Selector
- Hydraulic driven work bed with rollers for moving large material safely
- Three sets of vises design. The front and middle vises hold the stock during cutting while the guide vise can be separately controlled to guide the material during feeding cycle
- Stock position cylinder pushes stock away from fixed vise for easy material handling
- Shadow light for material measurement
- Blade breakage and/or slippage detector
- Bi-metal saw blade
- Tool box, leveling pads, and an additional wire brush
- Vibration damper
- Operation & parts manual
- Two (2) year limited warranty

Accessories

- BT01 Bandsaw Blade Tension Gauge
- CM5101H Chip Conveyor
- VP1201 Variable Vise Pressure System
- P10 Stock Stand Assembly 21" - 30"
- CSR1 SAWZIT 1 Gallon
- CSR5 SAWZIT 5 Gallon

Specifications

Model	H5167SA
Motor	20 Hp (11.2 kw), 230/460v 3ph*
Hydraulic Pump Motor	3 Hp (2.2 kw)
Hydraulic Oil Capacity	35 gallons (160 liters)
Blade Speeds (Variable Speed)	49-264 fpm (15-80 m/min)
Blade Size (W x T x L)	3.1" x .063" x 512" (80 x 1.6 x 13000mm)
Blade Tension	Hydraulic
Coolant	Recirculating
Coolant Capacity	44 gallons (200 liters)
90° Cutting Capacity	
Round	51" (1300mm)
Square	51" (1300mm)
Rectangular	51" x 67" (1300 x 1700mm)
Length	118" (3000mm)
Width	232" (5892mm)
Height	166.5" (4228mm)
Bed Height	24.4" (620mm)
Net Weight	48,500 lbs. (22000 kg)
Shipping Weight	51,410 lbs. (23320 kg)

*Other voltages optional.

Design and specifications are subject to change without notice.



Your Single Source for Machine Tools

Clausing Precision Drills

- Clausing Belt-drive Drills
- Clausing Geared-head Drills
- Clausing Radial Drills

Clausing Precision Mills

- Clausing Bed Mills
- Clausing CNC Bed Mills
- Clausing Knee Mills
- Clausing EVS Knee Mills
- Clausing Universal Mills

Clausing Precision Lathes

- Clausing/Colchester Geared Head Lathes
- Clausing/Colchester Professional V.S. Lathes
- Clausing/Metosa Geared Head & V.S. Lathes
- Clausing/Metosa CNC Lathes
- Clausing Large Swing Standard and CNC Lathes

Clausing Precision Grinders

- Clausing Manual Grinders
- Clausing 2 Axes Hydraulic Grinders
- Clausing 3 Axes Hydraulic Grinders
- Clausing ASDIII Automatic Grinders

Clausing Precision Cutting Machines

- Clausing/Kalamazoo Horizontal Bandsaws
- Clausing/Kalamazoo Vertical Bandsaws
- Clausing/Kalamazoo Cold Saws

For detailed catalogs of the full line of Clausing Machine Tools visit our Web Site:

www.clausing-industrial.com

or e-mail us and request an electronic (pdf) catalog at:

info@clausing-industrial.com

Your Authorized Clausing Precision Machine Tools Distributor



Clausing Industrial, Inc.
1819 North Pitcher Street
Kalamazoo, Michigan 49007-1886
Phone: 269-345-7155
Fax: 269-345-5945
Information: info@clausing-industrial.com

Call Toll Free: 800-323-0972
or visit our website
www.clausing-industrial.com