



## IBERDRILLS

**AFFORDABLE. DURABLE. VERSATILE.**

A full line of bench drilling machines, column drilling machines, and Multi-Head machines. Step pulley, geared head, mechanical variable speed, and electronic variable speed drives.

Multi-purpose use

Belt Drive

Speed range

Easy to run

Low maintenance

Attractive design



**K25**



<b>K18</b>	.700"	1/2"	.68 - 1.4Hp	MT 3	4.72"	3.93"	9.84"
<b>K25</b>	1.1"	3/4"	.95 - 1.8Hp	MT 3	4.72"	3.93"	9.84"



**KL25**

Standard column drilling machine



**KS18**

With Optional Hydroblock



**KS18**

With lead screw system

## STANDARD EQUIPMENT

- Depth scale and adjustable depth stop
- Worklight
- Automatic tool ejector
- Security microswitch on cover
- Thermo-magnetic motor breaker switch
- Emergency STOP push button
- Right-left turn
- Low voltage electric equipment
- Safety drill guard with microswitch
- CE mark

## OPTIONAL EQUIPMENT

- PKA Floor cabinet with 2 shelves (only for EKS and EKM models)
- PKB Floor cabinet with door and drawer (only for EKS and EKM models)
- RS Automatic feed reversing system for tapping
- VE Variable speed by electronic variator
- TAK Digital RPM counter for EVS models (must have inverter)
- LBC Depth scale digital read-out system
- ERB Coolant system in base
- VWH-K Hand wheel for fine feed work
- HB Hydroblock automatic feed system
- MG Rotating table (only for KM models)

# K SERIES SPECIFICATIONS

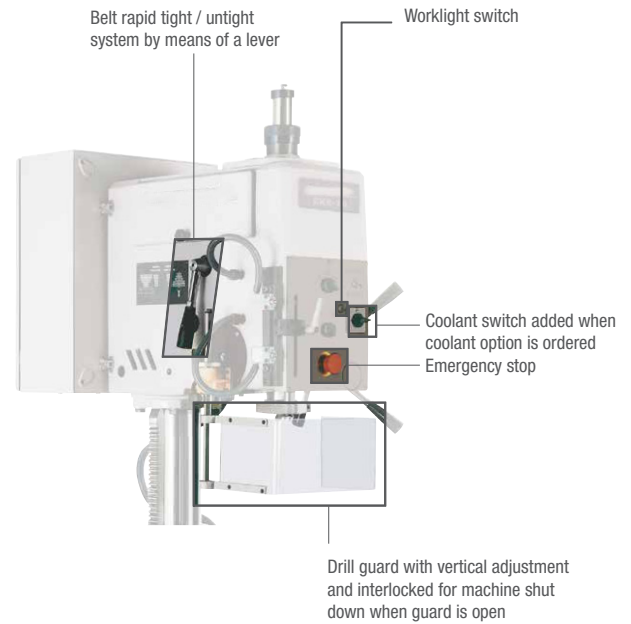
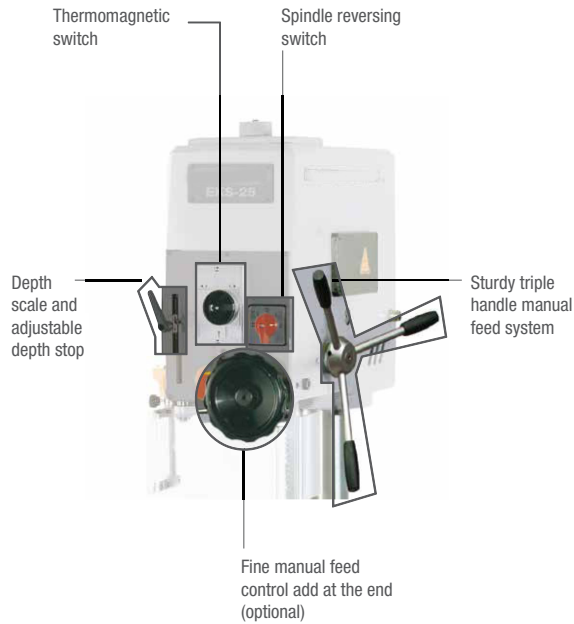

CHARACTERISTICS		KS18 KM18 KL18	KS25 KM25 KL25	KS30 KM30 KL50
Maximum drilling capacity in mild steel	Inch (mm)	.71 (18)	.98 (25)	1.18 (30)
Maximum tapping capacity in mild steel	Inch (mm)	1/2 (M14)	3/4 (M18)	1 (M25)
Morse Taper MT	MT		3	
Maximum spindle stroke (drilling depth)	Inch (mm)	4.72 (120)		
Main motor power	HP (kw)	0.68/1.4 (0.51/1.05)	0.95 - 1.8 (0.71 - 1.35)	1.2/2 (0.9/1.5)
Transmission		Belt		
Number of speeds		10		
Speed range with motor at 750/1500 rpm 50 Hz 3Ph Speed range with motor at 900/1800 rpm 60 Hz 3 Ph (standard)	[rpm]	245-355-490-710-835-1240-1670-2000-2480-4000 295-425-590-850-1000-1490-2000-2400-2980-4800		
Feed	Inch (mm)	Manual		
Worktable dimensions (LxW)	Inch (mm)	10.6x10.6 (270x270)(KS/KM18) 10.6x11.8 (270x300)(KL18)	10.6x10.6 (270x270)(KS/KM25) 10.6x11.8 (270x300)(KL25)	10.6x10.6 (270x270)(KS/KM30) 10.6x11.8 (270x300)(KL30)
Column diameter	Inch (mm)	3.93 (100)		
Distance from spindle centre to column face	Inch (mm)	9.84 (250)		
Net weight	LBS. (kg)	18 (190)      506 (230) 550 (250)-KL18	418 (190)      506 (230) 550 (250)-KL25	418 (190)      506 (230) 550 (250)-KL30
Shipping weight	LBS. (kg)	440 (200)      550 (250) 693 (315)-KL18	693 (315)      440 (200) 715 (325)-KL25	550 (250)      715 (325) 715 (325)-KL30
Shipping dimensions (length x width x height)	Inch	27.6x22.5x53.6    27.6x22.5x72.5 82.7x22.5x31.5(KL18 Lays Down)	27.6x22.5x53.6    27.6x22.5x72.5 82.7x22.5x31.5(KL25 Lays Down)	27.6x22.5x53.6    27.6x22.5x72.5 82.7x22.5x31.5(KL30 Lays Down)



**TM25**  
(shown with optional vise)

State of the art technology

Geared machine head

Speed range

Easy to run



T25    1"    3/4"    1 / 1.6Hp    MT 3    4.72"    3.94"    9.84"



With optional rotating table (MG-T)



With floor cabinet with 2 shelves (PKA).



With floor cabinet with door and drawer (PKB).

## STANDARD EQUIPMENT

- Depth scale and adjustable depth stop
- Worklight
- Automatic tool ejector
- Thermo-magnetic motor breaker switch
- Emergency STOP push button
- Right-left turn
- Low voltage electric equipment
- Safety drill guard with microswitch
- CE mark

## OPTIONAL EQUIPMENT

- PKA Floor cabinet with 2 shelves (only for TS and TM models)
- PKB Floor cabinet with door and drawer (only for TS and TM models)
- RS Automatic feed reversing system for tapping
- VE Variable speed by electronic variator
- TAK Digital RPM counter for EVS models (must have inverter)
- RPF Pitch controlled tapping with braking system by speed inverter
- HGP Master guide spindle and nut set (for multi head systems)
- HGP-S Special master guide spindle and nut set (for multi head systems)
- ERB Coolant system in base
- VWH-T Hand wheel for fine feed work
- HB Hydroblock automatic feed system
- MG Rotating table (only for TM and TL models)

# T SERIES SPECIFICATIONS

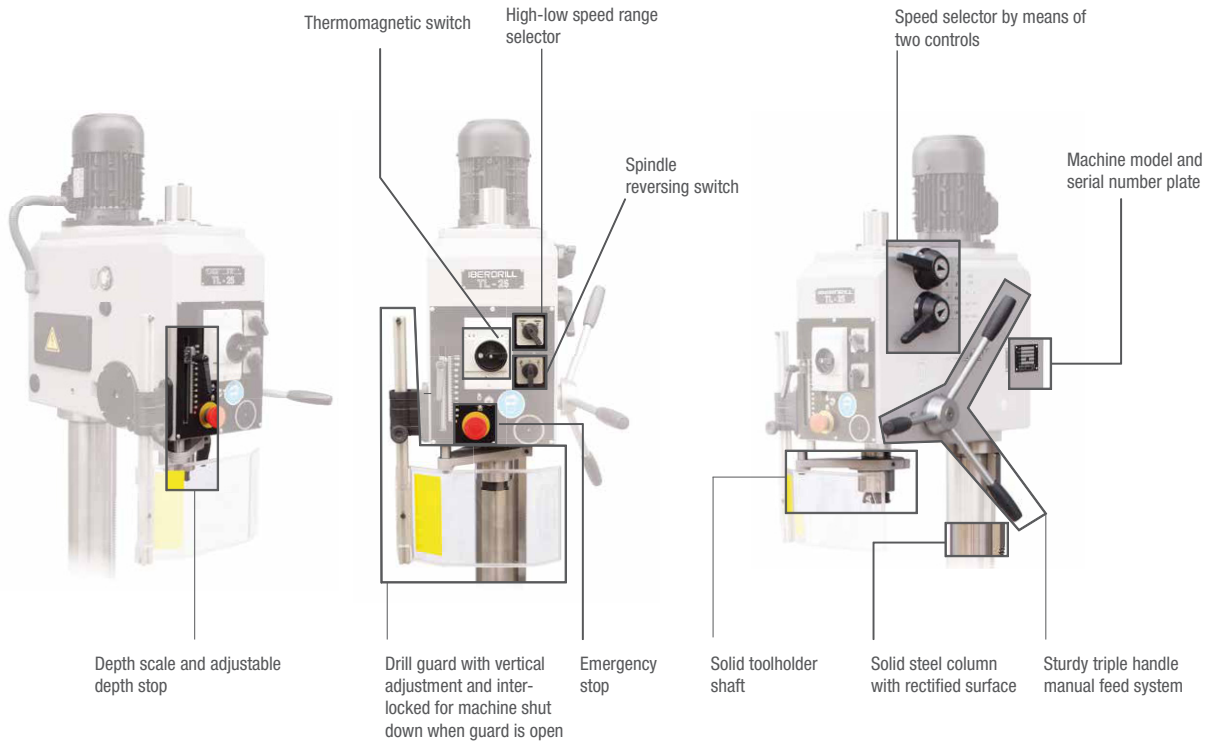

CHARACTERISTICS		TS25 TM25 TL25	TSA25 TMA25 TLA25	TS30 TM30 TL30	TSA30 TMA30 TLA30
Maximum drilling capacity in mild steel	Inch (mm)	1" (25)		1.18" (30)	
Maximum tapping capacity in mild steel	Inch (mm)	3/4" (M18)		1" (M25)	
Morse Taper MT	MT	3			
Maximum spindle stroke (drilling depth)	Inch (mm)	4.72 (120)			
Main motor power	HP (kw)	1.1/1.6 (0.82/1.2)		1.5/1.9 (1.13/1.43)	
Transmission		Gear box			
Number of speeds		8			
Speed range with motor at 1500/3000 rpm 50 Hz 3Ph Speed range with motor at 1800/3600 rpm 60 Hz 3 Ph (standard)	[rpm]	65-125-185-365-540-1055-1560-3060 78-150-222-438-648-1266-1872-3672			
Feed	Inch (mm)	Manual	Automatic	Manual	Automatic
Number of feeds		-	2	-	2
Automatic feed range	in/rev (mm/rev)	-	0.0039/.0078 (0.1/0.2)	-	0.0039/.0078 (0.1/0.2)
Worktable dimensions (LxW)	Inch (mm)	10.6x10.6 (270x270)(TS25) 11.8x10.6 (300x270)(TM/TL25)	10.6x10.6 (270x270)(TSA25) 11.8x10.6 (300x270)(TMA/TLA25)	10.6x10.6 (270x270)(TS30) 11.8x10.6 (300x270)(TM/TL30)	10.6x10.6 (270x270)(TSA30) 11.8x10.6 (300x270)(TMA/TLA30)
Column diameter	Inch (mm)	3.93 (100)			
Distance from spindle centre to column face	Inch (mm)	9.84 (250)			
Net weight	LBS. (kg)	440 (200kg) (TS & TSA25) 528 (240kg) (TM & TMA25) 550 (250kg) (TL & TLA25)		440 (200kg) (TS & TSA30) 528 (240kg) (TM & TMA30) 550 (250kg) (TL & TLA25)	
Shipping weight	LBS. (kg)	462 (210) (TS & TSA25) 572 (260) (TM & TMA25) 682 (310) (TL & TLA25)		462 (210) (TS & TSA30) 572 (260) (TM & TMA30) 682 (310) (TL & TLA30)	
Shipping dimensions (length x width x height)	Inch	31.5x23.7x57.1 (.8x.6x1.4)(TS25) 31.5x22.5x76 (.8x.57x1.93)(TM25) 86.7x23.7x35.5 (2.2x.6x.9)(TL25) (Lays Down)	31.5x23.7x57.1 (.8x.6x1.45)(TSA25) 31.5x22.5x76 .8x.57x1.93)(TMA25) 86.7x23.7x35.5 (2.2x.6x.9)(TLA25) (Lays Down)	31.5x23.7x57.1 (.8x.6x1.45)(TS30) 31.5x22.5x76 (.8x.57x1.93)(TM30) 86.7x23.7x35.5 (2.2x.6x.9)(TL30) (Lays Down)	31.5x23.7x57.1 (.8x.6x1.45)(TSA30) 31.5x22.5x76 (.8x.57x1.93)(TMA30) 86.7x23.7x35.5 (2.2x.6x.9)(TLA30) (Lays Down)



**Extremely quite running  
belt drive**

**Step Pulley Drive SZ Series,  
Variable Speed AZ Series**

**Suitable size and capacity**

**Easy to run**

**Low maintenance**



**Z32** 1.26" 7/8" 1.2/1.74 Hp MT 3 5.9" 4.92" 11.81"



*With optional rotating table  
plate and tilting support*



*(MGI-Z)  
With optional reversible tilting  
table (MGM-Z)*

## STANDARD EQUIPMENT

- Depth scale and adjustable depth stop
- Manual quill feed SZ series– Automatic quill feed operated by mechanical clutch AZ series.
- Thermomagnetic switch
- Emergency STOP push button
- Automatic tool ejector
- Spindle reversing switch
- Slow / fast speed selector
- Machined base with coolant tank
- Worklight
- Safety drill guard with microswitch
- CE mark

## OPTIONAL EQUIPMENT

- MGI Rotating table and tilting support
- MGM Reversible tiltable
- RS Automatic feed reversing system for tapping
- HB Hydroblock automatic feed system
- TAK Digital rpm counter (only for V models)
- SC Column riser (200mm)
- LBC Depth scale digital read-out system

# Z SERIES SPECIFICATIONS

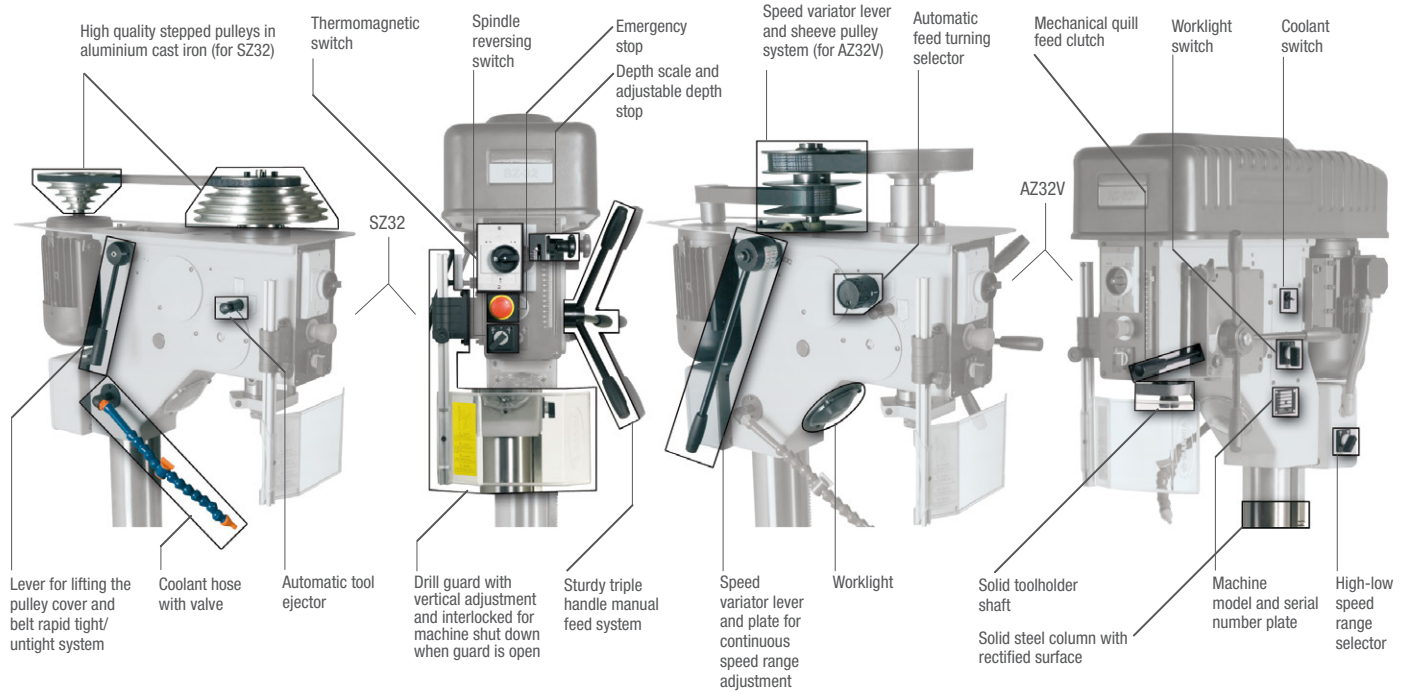

CHARACTERISTICS		SZ32	AZ32V
Maximum drilling capacity in mild steel	Inch (mm)	1.26 (32)	
Maximum drilling capacity in cast iron 200 Brinell	Inch (mm)	1.38 (35)	
Maximum tapping capacity in mild steel	Inch (mm)	7/8 (M22)	
Maximum tapping capacity in cast iron 200 Brinell	Inch (mm)	1-1/8 (M30)	
Morse Taper MT	MT	3	
Maximum spindle stroke (drilling depth)	Inch (mm)	5.9 (150)	
Main motor power	HP (kw)	1.2 / 1.8 (0.9/1.3)	
Coolant pump motor power	HP (kw)	0.1 (0.07)	
Transmission		Belt drive	
Number of speeds		10	Continuous
Speed range with motor at 750/1500 rpm 50 Hz Tri. Speed range with motor at 900/1800 rpm 60 Hz 3 Ph (standard)	[rpm]	145-220-290-345-440-540-690-860 1080-1720 174-264-348-414-528-648-828-1032-1296-2064	80-1170 95-1400
Feed	Inch (mm)	Manual	Mechanical Clutch
Number of automatic feeds		-	2
Automatic feed range	in/rev (mm/rev)	-	0.0039 / 0.0078 (0.1/0.2)
Worktable dimensions (LxW)	Inch (mm)	15.75 x 16.54 (400 x 420)	
Column diameter	Inch (mm)	4.92 (125)	
Distance from spindle centre to column face	Inch (mm)	11.81 (300)	
Net weight	LBS. (kg)	572 (260)	638 (290)
Shipping weight	LBS. (kg)	682 (310)	748 (340)
Shipping dimensions (length x width x height)	Inch	91 x 24 x 44 (2.3 x 0.6 x 1.1) (lays down)	



**Extremely quiet running belt drive**

**Electronic variable speed drive**

**Digital rpm counter**

**Automatic feed reversing for tapping**

**Easy to run**

**Low maintenance**



<b>Z34</b>	1.34"	1-1/8"	4 Hp	MT 4	5.9"	4.92"	11.81"
<b>Z40</b>	1.57"	1-3/8"	5.5 Hp	MT 4	7.0"	5.90"	13.77"



*With optional rotating/tilting table (MGI) Z34 series only*



*With optional reversible tilting table (MGM) SZ34 series only with vice (MGM).*

## STANDARD EQUIPMENT

- Electronic speed inverter
- Manual quill feed SZ series – Automatic quill feed operated by mechanical clutch AZ series, electromagnetic clutch BZ series.
- Speed setting potentiometer
- Digital rpm counter
- RS Automatic feed reversing system for tapping
- Depth scale and adjustable depth stop
- Automatic tool ejector
- Emergency STOP push button
- Rightwards turn push-button
- Leftwards turn push-button
- Electric equipment integrated on machine's head
- Machined base with coolant tank
- Worklight
- Safety drill guard with microswitch
- Fixed table only for 34 model
- Rotating and tilting table only for 40 model
- CE Mark

## OPTIONAL EQUIPMENT

- MGI Rotating table and tilting support (only for 34 models)
- MGM Reversible tilttable with vice (only for 34 models)
- ACNL Pneumatic counterbalance with rapid approach and retract (only for BZ models)
- CI Integral drilling cycle with encoder (only for BZ models)
- HB Hydroblock automatic feed system
- UC Union, dragging cone and assembly for multi-spindle head
- GM Multi-spindle head guide rod
- SC Column riser (7.87")
- CN Pneumatic counterbalance
- LBC Depth scale digital read-out system
- CM Auxiliary commanding box (Start-stop & Emergency stop) BZ40 series only
- MB Security bimanual command (only for BZ model)



# Z34/40 SERIES SPECIFICATIONS

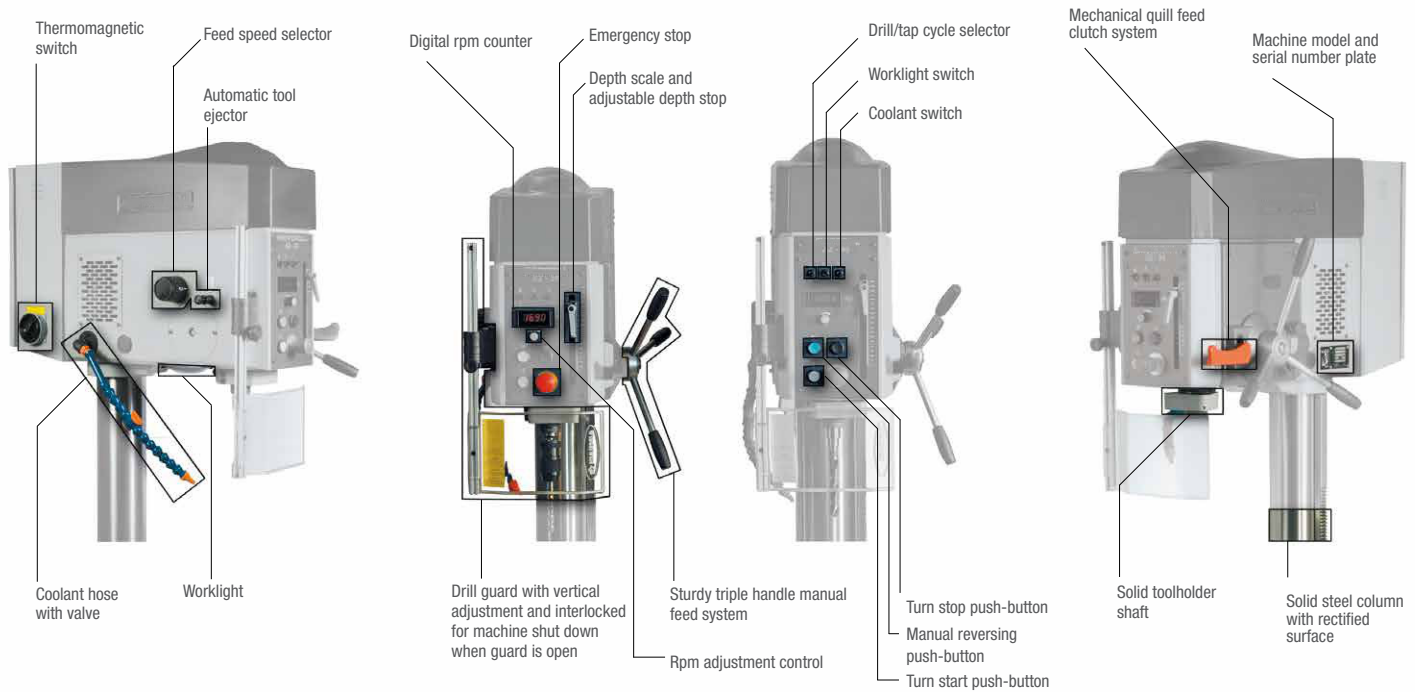

<b>CHARACTERISTICS</b>		<b>SZ32 AZ34 BZ34</b>			<b>SZ40 AZ40 BZ40</b>		
Maximum drilling capacity in mild steel	Inch (mm)	1.34 (34)			1.57 (40)		
Maximum drilling capacity in cast iron 200 Brinell	Inch (mm)	1.57 (40)			1.77 (45)		
Maximum tapping capacity in mild steel	Inch (mm)	1.125 (M27)			1.375 (M33)		
Maximum tapping capacity in cast iron 200 Brinell	Inch (mm)	1.375 (M33)			1.5 (M39)		
Morse Taper MT	MT	4					
Maximum spindle stroke (drilling depth)	Inch (mm)	5.90 (150)			6.89 (175)		
Main motor power	HP (kw)	4 (3)			5.5 (4.12)		
Coolant pump motor power	HP (kw)	0.1 (0.07)					
Transmission		Belt drive					
Number of speeds		Variable					
Speed variator type		Electronic					
Speed range with motor at 1500 rpm 50 Hz 3Ph. Speed range with motor at 1800rpm 60 Hz 3 Ph (standard)	[rpm]	100-2000 118-2360					
Feed	Inch (mm)	Manual	Automatic		Manual	Automatic	
Number of automatic feeds		-	3		-	3	
Automatic feed range	in/rev (mm/rev)	-	0.0039/0.0078/0.0118 (0.1/0.2/0.3)		-	0.0039/0.0078/0.0118 (0.1/0.2/0.3)	
Worktable dimensions (LxW)	Inch (mm)	15.74 x 16.54 (400 x420)			18.89 x 18.89 (480 x480)		
Column diameter	Inch (mm)	4.92 (125)			5.90 (150)		
Distance from spindle centre to column face	Inch (mm)	11.81 (300)			13.77 (350)		
Net weight	LBS. (kg)	759 (345)	792 (360)	814 (370)	979 (445)	1,012 (460)	1,034 (470)
Shipping weight	LBS. (kg)	869 (395)	902 (410)	924 (420)	1,089 (495)	1,122 (510)	1,144 (520)
Shipping dimensions (length x width x height)	Inch	90.55 x 23.62 x 43.31 (2.3 x0.6 x 1.1) (lays down)					



**Geared head drilling**

**Optimum mechanical system**

**Suitable size and capacity**

**Easy to run**

**Low maintenance**



**X32** 1.26" .875" 1.54 Hp MT 4 5.91" 4.92" 11.81"



*With optional rotating/tilting table (MGI)*



*With optional reversible tilting table (MGM)*

## STANDARD EQUIPMENT

- Manual quill feed SX series - Automatic quill feed operated by mechanical clutch AX series, electromagnetic clutch BX series.
- Hardened and ground high quality steel gears
- Speed plate and selecting levers on head front
- Depth scale and adjustable depth stop
- Thermomagnetic switch
- Emergency STOP push button
- Spindle reversing switch
- Machined base with coolant tank
- Worklight
- Fixed table
- Safety drill guard with microswitch
- CE mark

## OPTIONAL EQUIPMENT

- VS-X32 Continuous speed by electronic variator
- TAK Continuous speed by electronic variator digital rpm counter (requires VE-X32)
- MGI Rotating table and tilting support
- MGM Reversible tiltable with vice
- RS Automatic feed reversing system for tapping
- RPF Pitch controlled tapping with braking system by speed inverter
- HGP Master guide spindle and nut set
- HGP-S Special master guide spindle and nut set
- HB Hydroblock automatic feed system
- ACNL Pneumatic counterbalance with rapid approach and retract (only BX models)
- CI Integral drilling cycle with encoder (only BX models)
- UC Union, dragging cone and assembly for multi-spindle head
- GM Multi-spindle head guide rod
- CN Pneumatic counterbalance
- SC Column riser (7.87")
- CM Auxiliary commanding box (Start-stop & Emergency stop) (only BX models)
- LBC Depth scale digital read-out system
- MB Security bimanual command (only BX models)

# X32 SERIES SPECIFICATIONS

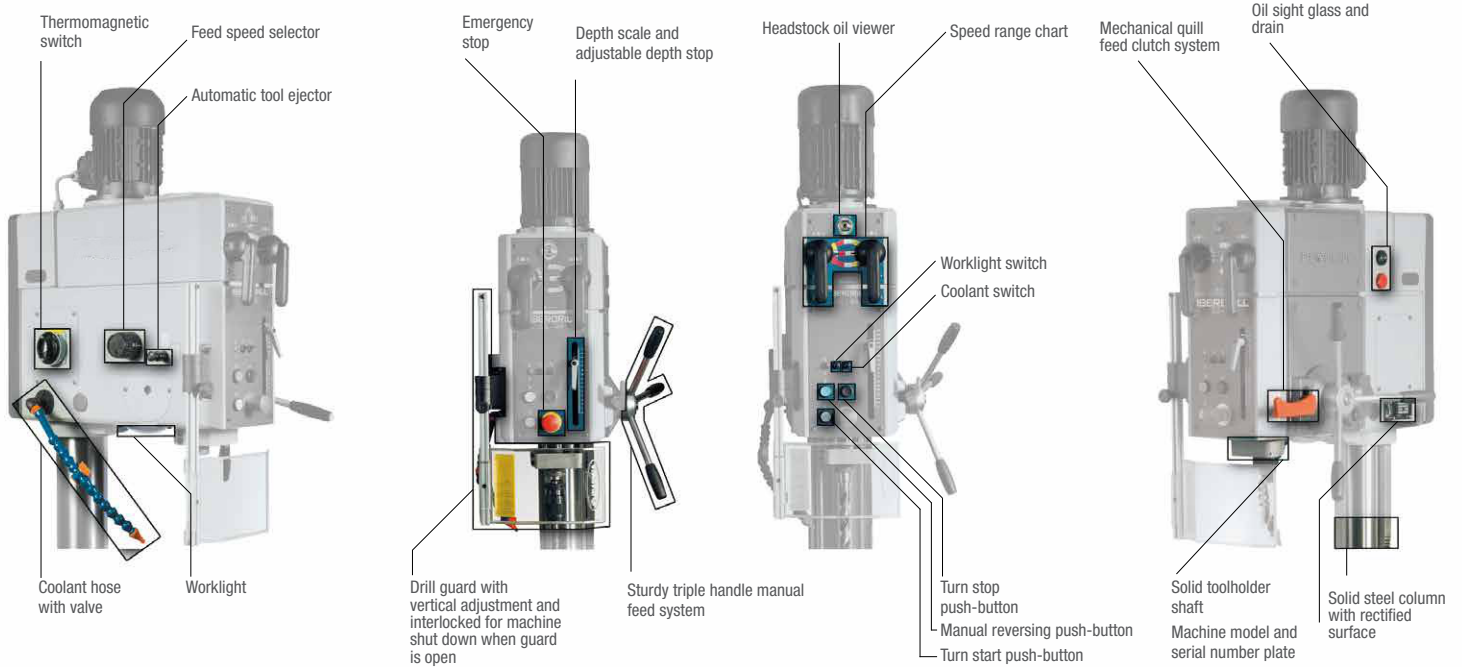

CHARACTERISTICS		SX32	AX32	BX32
Maximum drilling capacity in mild steel	Inch (mm)		1.26 (32)	
Maximum drilling capacity in cast iron 200 Brinell	Inch (mm)		1.38 (35)	
Maximum tapping capacity in mild steel	Inch (mm)		7/8 (M22)	
Maximum tapping capacity in cast iron 200 Brinell	Inch (mm)		5.91 (150)	
Morse Taper MT	MT		4	
Maximum spindle stroke (drilling depth)	Inch (mm)		5.91 (150)	
Main motor power	HP (kw)		1.5 (1.1)	
Coolant pump motor power	HP (kw)		0.1 (0.07)	
Transmission			Gear box	
Number of speeds			9	
Speed range with motor at 1500 rpm 50 Hz 3Ph Speed range motor at 1800 rpm 60 Hz 3 Ph (standard)	[rpm]		132-194-277-319-466-666-883-1296-1852 158-232-332-382-559-799-1059-1555-2222	
Feed	Inch (mm)	Manual	Automatic	Automatic
Number of automatic feeds		-	3	
Automatic feed range	in/rev (mm/rev)	-	0.0039/0.0078/0.0118 (0.1/0.2/0.3)	
Worktable dimensions (LxW)	Inch (mm)	15.75 x 16.54 (400 x 420)		
Column diameter	Inch (mm)	4.92 (125)		
Distance from spindle centre to column face	Inch (mm)	11.81 (300)		
Net weight	LBS. (kg)	847 (385)	880 (400)	902 (410)
Shipping weight	LBS. (kg)	957 (435)	990 (450)	1,012 (460)
Shipping dimensions (length x width x height)	Inch	91 x 24 x 44 (2.3 x 0.6 x 1.1) lays down		93x24x46 (2.34x0.61x1.16) lays down



**Geared head drilling**

**Designed for  
size and capacity**

**Easy to run**

**Low life**

**Mechanical reliability**



<b>X34</b>	1.34"	1"	2 Hp	MT 4	5.91"	4.92"	11.81"
<b>X40</b>	1.57"	1.25"	3 Hp	MT 4	7.09"	5.91"	13.78"



*With optional rotating/  
tilting table (MGI)*



*With optional reversible  
tilting table (MGM)*

## STANDARD EQUIPMENT

- Manual quill feed SX series - Automatic quill feed operated by mechanical clutch AX series, electromagnetic clutch BX series.
- Hardened and ground high quality steel gears
- Speed plate and selecting levers on head front.
- Depth scale and adjustable depth stop
- Automatic tool ejector
- Emergency STOP push button
- Spindle reversing switch
- Electric equipment integrated on machine's head
- Machined base with coolant tank
- Worklight
- MF: Fixed table for model 34
- MGI: Rotating and tilting table for model 40
- Safety drill guard with microswitch
- CE mark

## OPTIONAL EQUIPMENT

- MGI Rotating table and tilting support (only for 34 models)
- MGM Reversible tiltable with vice (only for X-34 model)
- RS Automatic feed reversing system for tapping
- RPF Pitch controlled tapping with braking system by speed inverter
- HGP-S Special master guide spindle and nut set
- ACNL Pneumatic counterbalance with rapid approach and retract (only for BX models)
- CI Integral drilling cycle with encoder (only for BX models)
- HB Hydroblock automatic feed system
- UC Union, dragging cone and assembly for multi-spindle head
- GM Multi-spindle head guide rod
- PM START/STOP/EMERGENCY control extension (only for BX models)
- CM Column riser (7.87")

# X34/40 SERIES SPECIFICATIONS

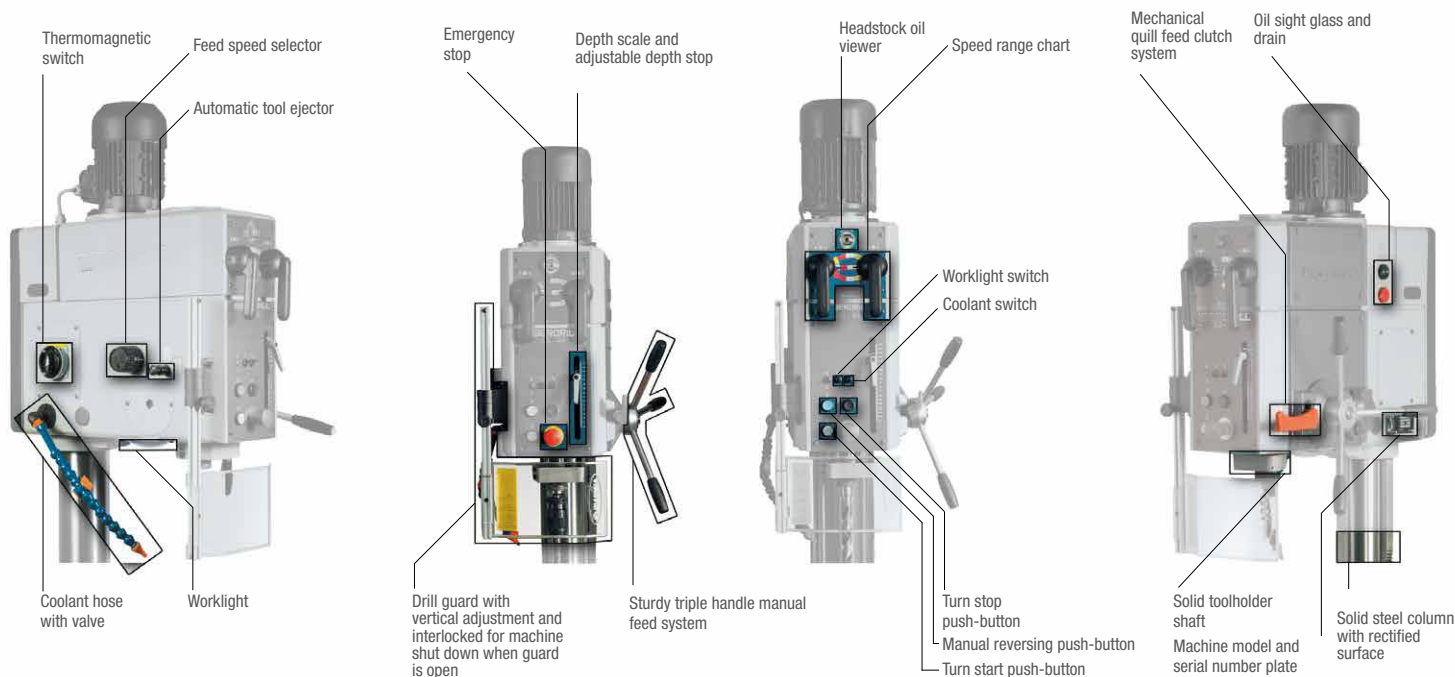

CHARACTERISTICS		SX34 AX34 BX32			SX40 AX40 BX40		
		Manual	Automatic		Manual	Automatic	
Maximum drilling capacity in mild steel	Inch (mm)	1.34 (34)			1.57 (40)		
Maximum drilling capacity in cast iron 200 Brinell	Inch (mm)	1.57 (40)			1.77 (45)		
Maximum tapping capacity in mild steel	Inch (mm)	1 (M27)			1.125 (M33)		
Maximum tapping capacity in cast iron 200 Brinell	Inch (mm)	1.125 (M33)			1.5 (M39)		
Morse Taper MT	MT	4					
Maximum spindle stroke (drilling depth)	Inch (mm)	5.90 (150)			6.89 (175)		
Main motor power	HP (kw)	2 (1.5)			3 (2.2)		
Coolant pump motor power	HP (kw)	0.1 (0.07)					
Transmission		Gear box					
Number of speeds		9					
Speed range with motor at 1500 rpm 50 Hz 3Ph. Speed range with motor at 1800rpm 60 Hz 3 Ph (standard)	[rpm]	132-194-277-319-466-666-883-1296-1852 158-232-332-382-559-799-1059-1555-2222					
Feed	Inch (mm)	Manual	Automatic		Manual	Automatic	
Number of automatic feeds		-	3		-	3	
Automatic feed range	in/rev (mm/rev)	-	0.0039/0.0078/0.0118 (0.1/0.2/0.3)		-	0.0039/0.0078/0.0118 (0.1/0.2/0.3)	
Worktable dimensions (LxW)	Inch (mm)	15.74 x 16.54 (400 x420)			18.89 x 18.89 (480 x480)		
Column diameter	Inch (mm)	4.92 (125)			13.77 (350)		
Distance from spindle centre to column face	Inch (mm)	11.81 (300)			13.77 (350)		
Net weight	LBS. (kg)	847 (385)	880 (400)	902 (410)	1,045 (475)	1,078 (490)	1,100 (500)
Shipping weight	LBS. (kg)	957 (435)	990 (450)	1,012 (460)	1,155 (525)	1,188 (540)	1,210 (550)
Shipping dimensions (length x width x height)	Inch	91 x 24 x 44 (2.3 x .6 x 1.1) (lays down)					



**Geared head drilling**

**Many industrial uses**

**Durability and long life**

**Real capacity**



<b>A40</b>	1.57	1.25	3 Hp	MT 4	7.87	6.89	14.17
<b>A50</b>	1.97	1.375	4 Hp	MT 4	9.06	9.06	15.75



*With rotating table plate and tilting support (MGI).*

## STANDARD EQUIPMENT

- Hardened and ground high quality steel gears
- Speed plate and selecting levers on head front
- Gear box lubrication by automatic pump
- Machined base with coolant tank
- Worklight
- Rotating table plate
- Automatic quill feed operated by mechanical clutch.
- Front hand wheel for fine feed work
- MGI Rotating and tilting table
- Depth scale and adjustable depth stop
- Automatic tool ejector
- Electric equipment integrated on machine's head
- Emergency STOP push button
- Spindle reversing switch
- Safety drill guard with microswitch
- CE mark

## OPTIONAL EQUIPMENT

- RS Automatic feed reversing system for tapping
- RPF Pitch controlled tapping with braking system by speed inverter
- HGP Master guide spindle and nut set
- HGP-S Special master guide spindle and nut set
- AR 50% lowered feed rate range
- CN Pneumatic counterbalance
- UC Union, dragging cone and assembly for multi-spindle
- GM Multi-spindle head guide rod
- SC Column riser (7.87")
- VE Variable speed by electronic variator
- TAK Continuous speed by electronic variator with automatic turn reversing system for tapping and digital rpm counter. TAK Digital RPM counter requires VE
- LBC Depth scale digital read-out system

# A SERIES SPECIFICATIONS

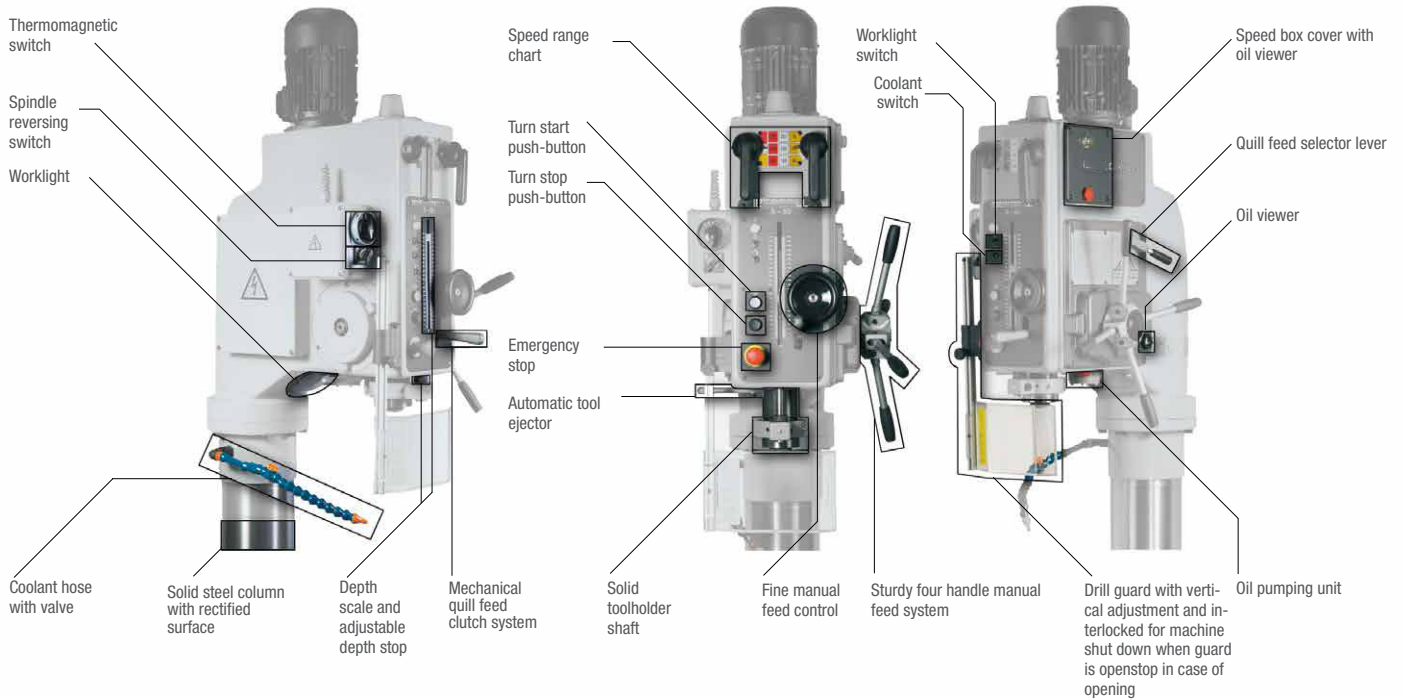

CHARACTERISTICS		A40	A50
Maximum drilling capacity in mild steel	Inch (mm)	1.57 (40)	1.97 (50)
Maximum drilling capacity in cast iron 200 Brinell	Inch (mm)	1.97 (50)	2.36 (60)
Maximum tapping capacity in mild steel	Inch (mm)	1.375 (M33)	1.5 (M36)
Maximum tapping capacity in cast iron 200 Brinell	Inch (mm)	1.625 (M40)	1.75 (M42)
Morse Taper MT	MT	4	
Maximum spindle stroke (drilling depth)	Inch (mm)	7.87 (200)	9.06 (230)
Main motor power	HP (kw)	3 (2.2)	4 (3)
Coolant pump motor power	HP (kw)	0.1 (0.07)	
Transmission		Gear box	
Number of speeds		9	
Speed range with motor at 1500 rpm 50 Hz 3Ph. Speed range with motor at 1800rpm 60 Hz 3 Ph (standard)	[rpm]	61-85-123-191-269-3900-574-806-1169 73-102-147-229-322-468-688-967-1402	54-75-1090-169-237-3440-507-712-1032 64-90-130-202-284-412-608-854-1238
Feed		Automatic by mechanical clutch	
Number of automatic feeds		4	
Automatic feed range	in/rev (mm/rev)	0.0039/0.0079/0.0118/0.0157 (0.1/0.2/0.3/0.4)	
Worktable dimensions (LxW)	Inch (mm)	21.65 x 21.65 (550 x 550)	
Column diameter	Inch (mm)	6.89 (175)	7.87 (200)
Distance from spindle centre to column face	Inch (mm)	14.17 (360)	15.75 (400)
Net weight	LBS. (kg)	1,342 (610)	1,562 (710)
Shipping weight	LBS. (kg)	1,529 (695)	1,749 (795)
Shipping dimensions (length x width x height)	Inch	99x24x48 (2.5x.6x1.2) (lays down)	104x24x48 (2.6x.6x1.2) (lays down)



With rotating table plate and tilting support (MGI)

**Geared head drilling**

---

**Various industrial uses**

---

**Variety of sizes**

---

**Real capacity**

---

**Long operation life**



<b>B40</b>	1.57"	1.375"	3 Hp	MT 4	7.87"	6.89"	14.17"
<b>B50</b>	1.97"	1.5"	4 Hp	MT 4	9.06"	7.87"	15.75"
<b>B60</b>	2.36"	1.75"	5.5 Hp	MT 5	10.24"	8.66"	16.54"
<b>B70</b>	2.75"	2"	7.5 Hp	MT 5	10.24"	8.66"	16.54"

## STANDARD EQUIPMENT

- Hardened and group high quality steel gears
- Speed plate and selecting levers on head
- Gear box lubrication by automatic pumps
- Machine base with coolant tank and pump
- Worklight
- MGI Rotating and tilting table
- Automatic quill feed operated by electromagnetic clutch.
- Front hand wheel for fine feed work
- Depth scale and adjustable depth stop
- Automatic tool ejector
- Electric equipment integrated on machine's head
- Emergency STOP push button
- Spindle reversing switch
- Safety drill guard with microswitch
- CE mark

## OPTIONAL EQUIPMENT

- RS Automatic feed reversing system for tapping
- RPF Pitch controlled tapping with braking system by speed inverter
- TAK Digital rpm counter
- HGP Master guide spindle and nut set
- HGP-S Special master guide spindle and nut set
- ACNL Pneumatic counterbalance with rapid approach and retract
- CI Integral drilling cycle with encoder
- AR 50% lowered feed rate range
- CN Pneumatic counterbalance
- UC Union, dragging cone and assembly for multi-spindle head
- GM Multi-spindle head guide rod
- CM START/STOP/EMERGENCY control extension
- SC Column riser (7.87")
- VE Variable speed by electronic variator
- LBC Depth scale digital read-out system
- MB Security bimanual command



# B SERIES SPECIFICATIONS

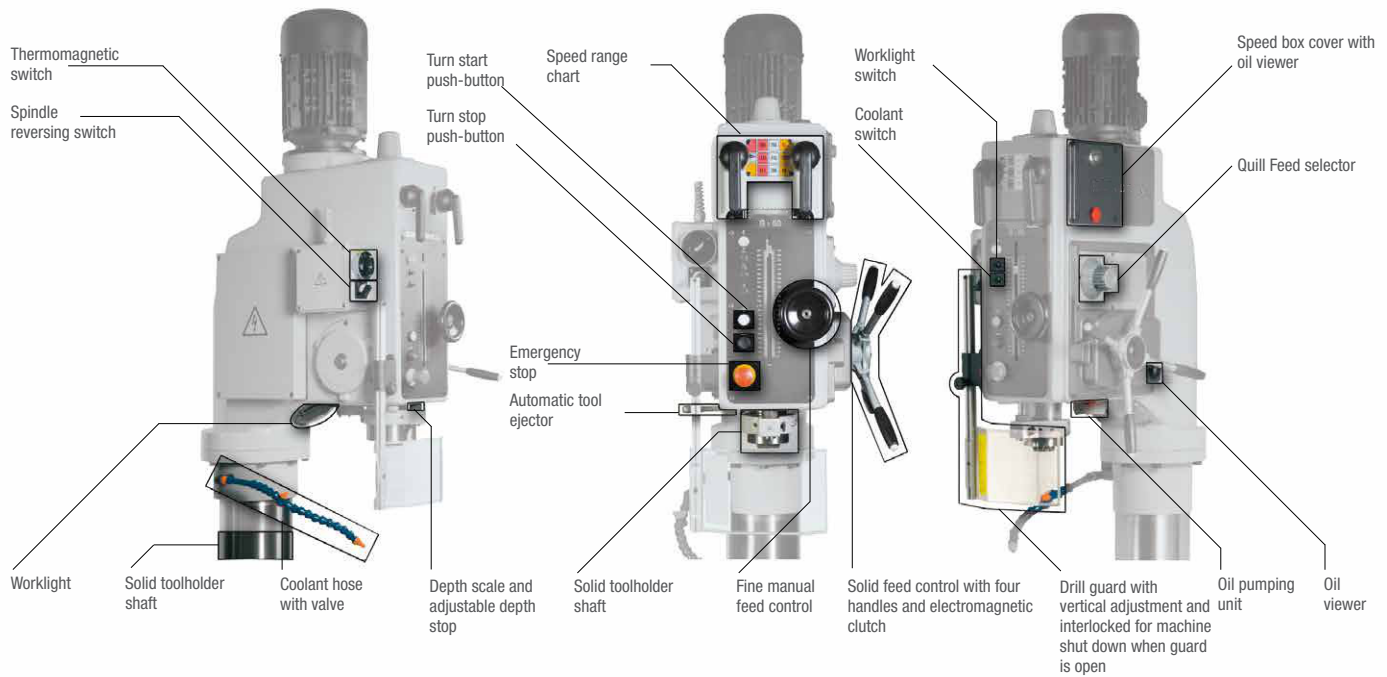

CHARACTERISTICS		B40	B50	B60	B70
Maximum drilling capacity in mild steel	Inch (mm)	1.57 (40)	1.97 (50)	2.36 (60)	2.75 (70)
Maximum drilling capacity in cast iron 200 Brinell	Inch (mm)	1.97 (50)	2.36 (60)	2.75 (70)	3.15 (80)
Maximum tapping capacity in mild steel	Inch (mm)	1.375 (M33)	1.5 (M36)	1.75 (M42)	2 (M50)
Maximum tapping capacity in cast iron 200 Brinell	Inch (mm)	1.625 (M40)	1.75 (M42)	2 (M50)	2.36 (M60)
Morse Taper MT	MT	4		5	
Maximum spindle stroke (drilling depth)	Inch (mm)	7.87 (200)	9.06 (230)	10.24 (260)	10.24 (260)
Main motor power	HP (kw)	3 (2.2)	4 (3)	5.5 (4)	7.5 (5.5)
Coolant pump motor power	HP (kw)	0.1 (0.07)		0.12 (0.09)	
Transmission		Gear box			
Number of speeds		9		12	
Speed range with motor at 1500/3000 rpm 50 Hz 3Ph	[rpm]	61-85-123-191-269-390-574-806-1169	54-75-109-169-237-344-507-712-1032	64-80-106-138-199-248-328-429-561-701-926-1210	51-64-84-110-158-198-262-342-447-559-738-966
Speed range with motor at 1800 rpm 60 Hz 3 Ph (standard)		73-102-147-229-322-468-688-967-1402	64-90-130-202-284-412-608-854-1238	76-96-127-165-238-297-393-514-673-841-1111-1452	61-76-100-132-189-237-314-410-536-670-885-1159
Feed		Automatic by electromagnetic clutch			
Number of feeds		4		6	
Automatic feed range	in/rev (mm/rev)	0.0039/0.0078/0.0118/0.0157 (0.1/0.2/0.3/0.4)	0.0039/0.0078/0.0118/0.0157/0.0197/0.0236 (0.1/0.2/0.3/0.4/0.5/0.6)		
Worktable dimensions (LxW)	Inch (mm)	21.65 x 21.65 (550 x 550)		23.62 x 23.62 (600 x 600)	
Column diameter	Inch (mm)	6.89 (175)	7.87 (200)	8.66 (220)	
Distance from spindle centre to column face	Inch (mm)	14.17 (360)	15.75 (400)	16.54 (420)	
Net weight	LBS. (kg)	1,342 (610)	1,584 (720)	1,804 (820)	1,848 (840)
Shipping weight	LBS. (kg)	1,529 (695)	1,771 (805)	2,024 (920)	2,068 (940)
Shipping dimensions (length x width x height)	Inch	99x24x48 (2.5x.6x1.2) (Lays down)	103x24x48 (2.6x.6x1.2) (Lays down)	107x28x48 (2.7x.7x1.2) (Lays down)	



**Belt driven gear head drive**

**Spindle reverse for tapping**

**Easy to run**

**State of the art technology**

**Wide range of industrial uses**



<b>BC40</b>	1.57"	1.5"	4 Hp	MT 4	7.87"	6.89"	14.17"
<b>BC50</b>	1.97"	1.750"	5.5 Hp	Mt 4	7.87"	6.89"	14.17"

## STANDARD EQUIPMENT

- Wide continuous speed range in 3 steps
- Speed plate and selecting levers on head front
- Mechanical speed variator in "V" model
- Electronic speed variator in "VE" model
- Digital rpm counter in front "VE"
- Gear box lubrication by automatic pump
- Machine base with coolant tank and pump for tapping
- Worklight
- MGI Rotating and tilting table
- Automatic quill feed operated by electromagnetic clutch
- Front hand wheel for fine feed work
- Depth scale and adjustable depth stop
- Automatic feed reversing system for tapping
- Automatic tool ejector
- Electric equipment integrated on machine's head.
- Emergency STOP push button
- Spindle reversing switch
- Safety drill guard with microswitch
- CE mark

## OPTIONAL EQUIPMENT

- AR 50% lowered feed rate range
- LBC Depth scale digital read-out system

# C SERIES SPECIFICATIONS

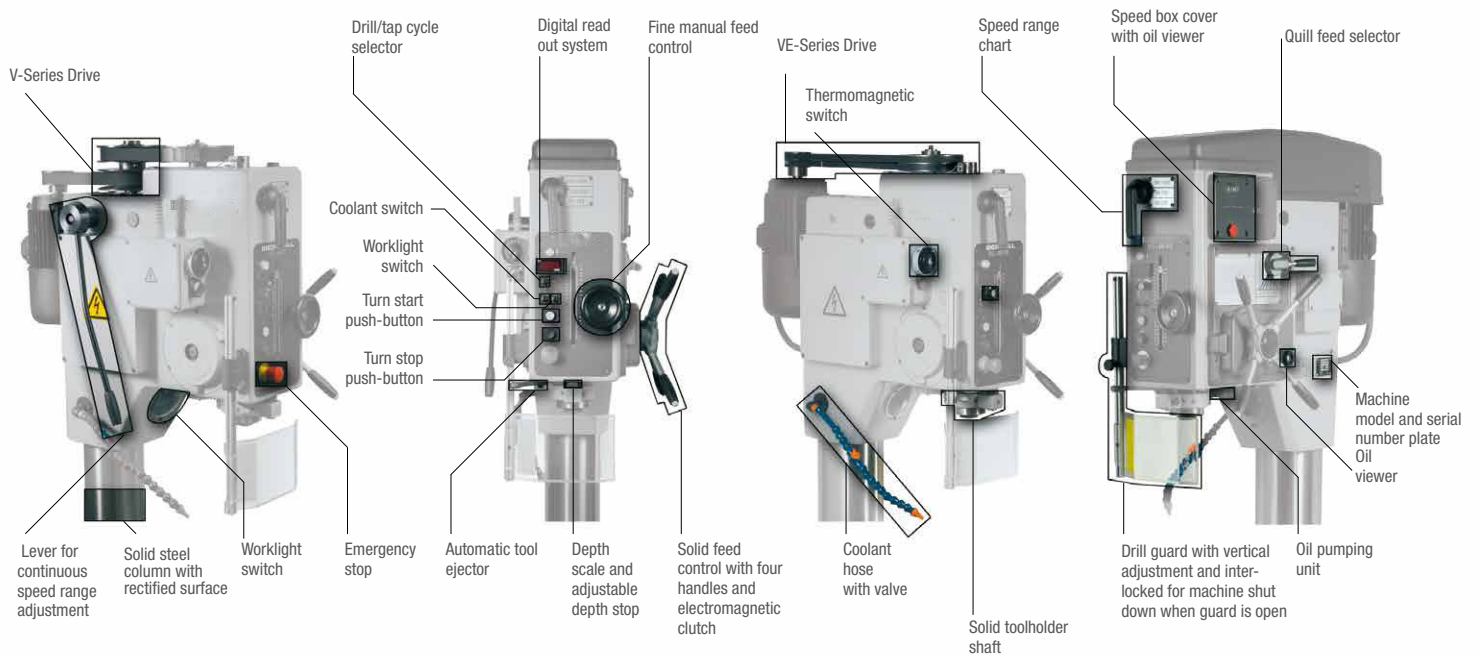

CHARACTERISTICS		BC40	BC40VE	BC50	BC50VE
Maximum drilling capacity in mild steel	Inch (mm)	1.57		1.97	
Maximum drilling capacity in cast iron 200 Brinell	Inch (mm)	1.97		2.36	
Maximum tapping capacity in mild steel	Inch (mm)	1.5		1.75	
Maximum tapping capacity in cast iron 200 Brinell	Inch (mm)	1.75		2	
Morse Taper MT	MT	4			
Maximum spindle stroke (drilling depth)	Inch (mm)	7.87		7.87	
Main motor power	HP (kw)	4 (3)		5.5 (4)	
Coolant pump motor power	HP (kw)	0.1 (0.07)			
Transmission		Belt / Gear			
Number of speeds		Continuous			
Speed variator type		Mechanical	Electronic	Mechanical	Electronic
Speed range with motor at 1500/3000 rpm 50 Hz 3Ph	[rpm]	72-240	36-360	72-240	36-360
Speed range with motor at 1800 rpm 60 Hz 3 Ph (standard)		240-720 720-1800	108-1080 228-2280	240-720 720-1800	108-1080 228-2280
Feed		Automatic by electromechanical clutch			
Number of feeds		4			
Automatic feed range	in/rev (mm/rev)	0.0039/0.0078/0.0118/0.0157 (0.1/0.2/0.3/0.4)			
Worktable dimensions (LxW)	Inch (mm)	21.65 x 21.65 (550 x 550)			
Column diameter	Inch (mm)	6.89 (175)			
Distance from spindle centre to column face	Inch (mm)	14.17 (360)			
Net weight	LBS. (kg)	1,452 (660)		1,672 (760)	
Shipping weight	LBS. (kg)	1,650 (750)		1,870 (850)	
Shipping dimensions (length x width x height)	Inch	87x28x48 (2.2x.7x1.2) (Lays down)		87x28x52 (2.2x.7x1.3) (Lays down)	



**The most power in a prismatic head**

**Precision**

**Productivity**

**Mechanical reliability**

**Technology**

**Various industrial uses**

**Durability and long life**



**BP50** 1.97" 1.875" 5.5 Hp MT 4 9.45" 18.11"

## STANDARD EQUIPMENT

- Adjusting of the vertical position of the head by geared-motor
- Hardened and ground high quality steel gears
- Gear box lubrication by automatic pump
- Automatic guide greasing by manual pump
- Coolant tank and pump in machine base
- Worklight
- Fixed worktable
- Automatic quill feed operated by electromagnetic clutch.
- Front hand wheel for fine feed work
- Depth scale and adjustable depth stop.
- Automatic tool ejector
- Electric equipment integrated on machine's head.
- Rightwards turn push button
- Leftwards turn push button
- Safety drill guard with microswitch
- CE mark

## OPTIONAL EQUIPMENT

- RPF Pitch controlled tapping with braking system by speed inverter
- HGP Master guide spindle and nut set
- HGP-S Special master guide spindle and nut set
- ACNL Pneumatic counterbalance with rapid approach and retract
- ACNL-2 Pneumatic counterbalance with rapid approach and retract (2 cylinder)
- CI Integral drilling cycle with encoder
- CN Pneumatic counterbalance
- UC Union, dragging cone and assembly for multi-spindle head
- GM Multi-spindle head guide rod
- GM2 Multi-spindle head guide rod (with 2 axis)
- ISO-40 ISO-40 spindle (only 50 models)

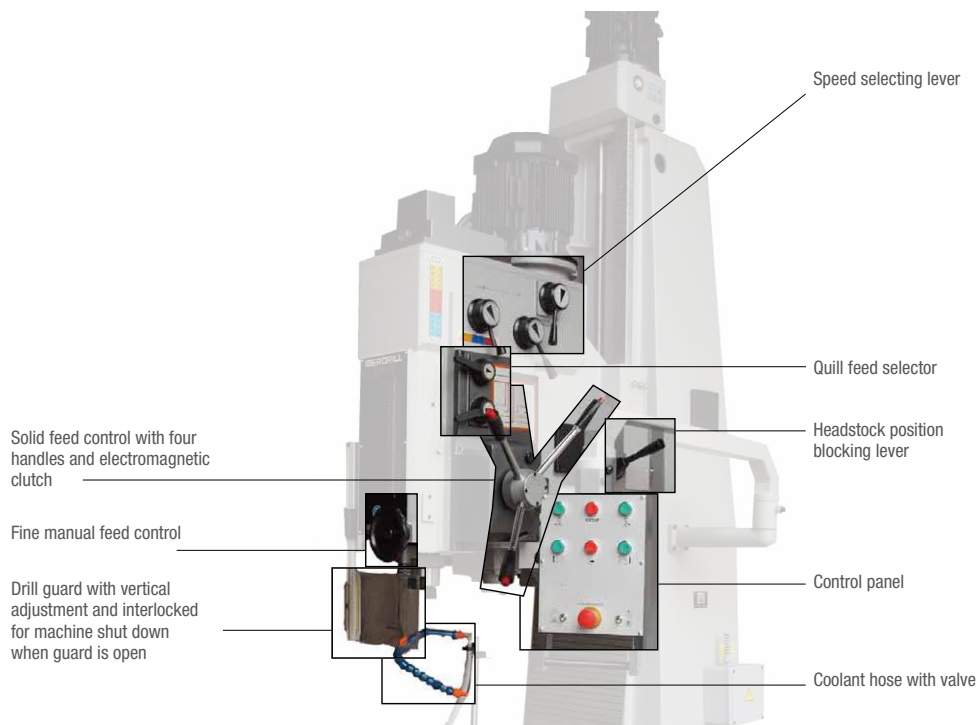

CHARACTERISTICS		BP50
Maximum drilling capacity in mild steel	Inch (mm)	1.97 (50)
Maximum tapping capacity in mild steel	Inch (mm)	9.45 (240)
Morse Taper	MT	4
ISO Taper (optional)	ISO/NMTB	40
Maximum spindle stroke (drilling depth)	Inch (mm)	9.45 (240)
Main motor power	HP (kw)	5.5 (4)
Coolant pump motor power	HP (kw)	0.12 (0.09)
Rise and falling head geared-motor power	HP (kw)	1.5 (1.1)
Transmission		Gear box
Number of speeds		9
Speed range with motor at 1500 rpm 50 Hz 3Ph. Speed range with motor at 1800rpm 60 Hz 3 Ph (standard)	[rpm]	68-100-150-200-295-440-565-855-1270 82-120-180-240-354-528-722-1098-1524
Feed		Automatic by electromagnetic clutch
Number of automatic feeds		4
Automatic feed range	in/rev (mm/rev)	0.0039/0.0079/0.0118/0.0157 (0.1/0.2/0.3/0.4)
Worktable dimensions (LxW)	Inch (mm)	31.50 x 23.62 (800 x 600)
Distance from spindle centre to column face	Inch (mm)	18.11 (460)
Net weight	LBS. (kg)	2,970 (1350)
Shipping weight	LBS. (kg)	4,070 (1850)
Shipping dimensions (length x width x height)	Inch	102 x 39 x 67 (2.58 x .98 x 1.7)



**Prismatic column series**

**Multi-functional uses**

**Precision and durability**

**Large travel cross table**



**BF35**    1.38"    2.74 cu/in    1.25"    1.25 Hp / 2 Hp    MT 4    7.09 (drill depth)    15.07"

## STANDARD EQUIPMENT

- Adjusting of the vertical position of the head by geared-motor
- 45° tilting head on both sides of the central axis
- Hardened and ground high quality steel gears
- Gear box lubrication by automatic pump
- Automatic guide greasing by manual pump
- High/low speed range selector
- Coolant tank and pump in machine base
- Worklight
- Co-ordinate cross table
- Automatic quill feed operated by electromagnetic clutch.
- Front hand wheel for fine feed work
- Depth scale and adjustable depth stop
- Automatic tool ejector
- Electric equipment integrated on machine's head
- Emergency STOP push button
- Spindle reversing switch
- Safety drill guard with microswitch
- CE mark

## OPTIONAL EQUIPMENT

- RS Automatic feed reversing system for tapping
- RPF Pitch controlled tapping with braking system by speed inverter
- HGP Master guide spindle and nut set
- HGP-S Special master guide spindle and nut set
- MT-4 Morse taper spindle
- ISO-40 ISO-40 spindle
- SC Column riser
- ENG X Motorized geared box feed system in X axis
- ENG Y Motorized geared box feed system in Y axis
- LDG-1 Digital read-out system for table axis (X) (Available also for 2 and 3 axis)
- MB Security bimanual command
- LBC Depth scale digital read-out system

# F SERIES SPECIFICATIONS

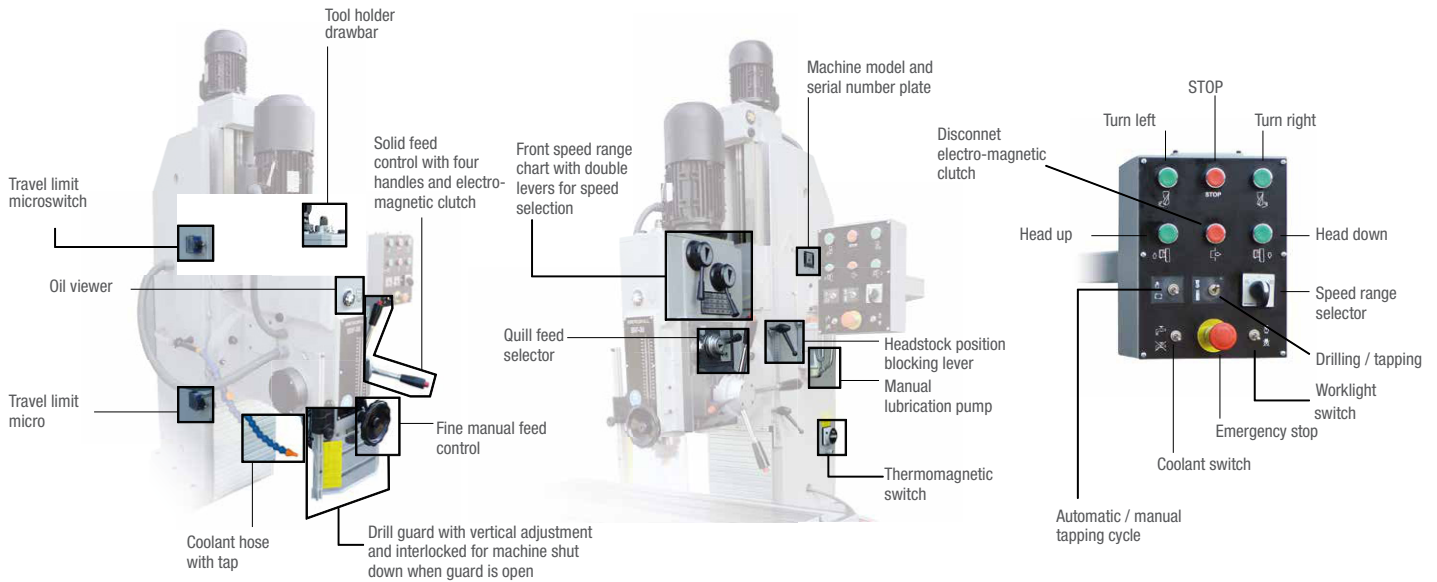

CHARACTERISTICS		BF35
Maximum drilling capacity in mild steel	Inch (mm)	1.38 (35)
Maximum milling capacity in mild steel	Inch (mm)	3.05 (55)
Maximum tapping capacity in mild steel	Inch (mm)	1.38 (35)
ISO Taper (optional)	ISO/NMTB	30
Morse Taper	MT	4
Maximum spindle stroke (drilling depth)	Inch (mm)	7.09 (180)
Main motor power	HP (kw)	1.2/2 (0.9/1.5)
Transmission		Gear box
Number of speeds		16
Speed range with motor at 750/1500 rpm 50 Hz 3Ph.	[rpm]	94-135-207-303-347-497-760-1112 189-271-416-606-695-995-152-2225
Speed range with motor at 1800rpm 60 Hz 3 Ph (standard)		113-162-248-363-417-597-912-1335 226-324-496-726-834-1194-1824-2670
Feed		Automatic by electromagnetic clutch
Number of automatic feeds		3
Automatic feed range	in/rev (mm/rev)	0.0039/0.0071/0.0094 (0.1/0.18/0.24)
Worktable dimensions (LxW)	Inch (mm)	14.17 x 48.03 (360 x 1220)
Longitudinal movement of the table (X)	Inch (mm)	27.56 (700)
Cross movement of the table (Y)	Inch (mm)	14.17 (360)
Distance from spindle centre to column face	Inch (mm)	15.35 (390)
Net weight	LBS. (kg)	2,002 (910)
Shipping weight	LBS. (kg)	3,080 (1400)
Shipping dimensions (length x width x height)	Inch	63 x 63 x 100 (1.68 x 1.68 x 2.52)

## CABINETS / BASES / CONTAINERS / LIGHT



**PKA**  
Floor cabinet with 2 shelves.  
Available for **K/T** series.



**PKB**  
Floor cabinet with door and drawer.  
Available for **K/T** series.

## TABLES INCLUDING SUPPORTS



**MF**  
Fixed table.  
Standard for **K/T/Z/X(32-34)** series.



**MG**  
Rotating table plate.  
Optional for **KL/TL** series.



**MGI**  
Rotating table plate and tilting support.  
Available for **Z/X/A/B/C** series.



**MGM**  
Reversible rotating tiltable  
Available for **Z/X (32/34)** series.



## CROSS TABLES



**MB1**  
Cross table.  
X = 8.66" (220 mm)  
Y = 5.5" (140 mm)  
Table net weight = 25 kg.  
Available for **K/T** series.

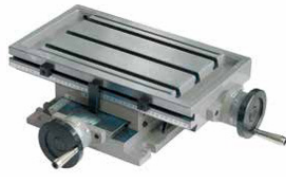

**MB2**  
Cross table.  
X = 11" (280 mm)  
Y = 7.09" (180 mm)  
Table net weight = 40 kg.  
Available for **Z/X** series.



**MB3**  
Cross table.  
X = 15.75" (400 mm)  
Y = 7.09" (180 mm)  
Table net weight = 52 kg.  
Available for **Z/X(32-34)** series.



**MB4**  
Cross table.  
X = 19.69" (500 mm)  
Y = 9.84" (250 mm)  
Table net weight = 93 kg.  
Available **Z/X/A/B/C** series.



**MB5**  
Cross table.  
X = 27.56" (700 mm)  
Y = 9.84" (250 mm)  
Table net weight = 150 kg.  
Available for **Z/X(40)/A/B/C** series.



**PST**  
Cycle or spindle turn START foot pedal.  
**PSR**  
Spindle turn reverse foot pedal (for tapping)



**PMC**  
Pendent control panel (all functions).  
Available for **P** series.



**ERB**  
"T" slotted machine base with coolant pump.  
Standard for **Z/X/A/B/C**  
Optional for **K/T** series.



**PV**  
Safety drill guard against chips with a micro-switch.  
**Standard in all series.**



**EL**  
Worklight.  
**Standard in all series**

## SPEED CONTROL / MEASURE / TAPPING



### Inverter drive system

Standard for **Z(34-40)**, **BC-40VE** and **BC-50VE**.  
Available for other models upon request.



### TAK

Digital rpm counter.  
Standard for **Z (34-40)** and **C** series.  
Optional on other models.



### LBC

Depth scale read-out system.  
Available for all series.

## SPEED CONTROL / MEASURE / TAPPING



### CN

Pneumatic counterbalance for spindle return (recommended with multi-spindle head applications). Available for **X/A/B/P** series.



### ACNL

Automatic drilling cycle with rapid approach, working feed and rapid retract. Available for **B** models on **Z/X/B/P** series.



### CI

Integral drilling cycle with encoder (recommended for tube and profile drilling, deep drilling operations, etc.). Available for **B** models on **Z/X/B/P** series.

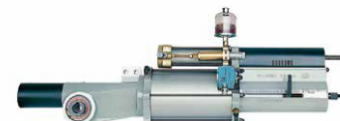

### HB

Hydro-pneumatic power feed unit. Available for **EK/T/Z/X** series (only for manual feed models).

## STANDARD ASSEMBLY FOR JOBS USING MULTI-SPINDLE HEADS

### Accessories and functions

**ACNL** Automatic drilling cycle with rapid approach, working feed and rapid retract, with additional pneumatic counterweight function for the multi-spindle head.

**UC** Union, dragging cone and assembly of the multi-spindle head.

**CM** Multi-spindle head with fixed or adjustable (see picture) spindles.

**GM** Multi-spindle head guide rod.

**PM** START/STOP and emergency STOP control extension.

**SC** Column riser of 200 mm for greater distance between spindle nose and worktable.



**RS**  
Automatic feed reversing for tapping.  
Standard for **Z(34-40)** and **C** series.  
Available for all series and all series models ending in RS.



**RPF**  
Automatic tapping cycle by lead screw system with brake motor for spindle reverse.  
Available for **X/A/B/P** series.



**HGP**  
Master guide spindle and nut set.  
Available for **X/A/B/P** series.



**CM**  
Multi-spindle drilling heads with fixed or adjustable spindles. Available for all series.



**AR**  
50% lowered feed rate range. Available for **A/B/C** series.

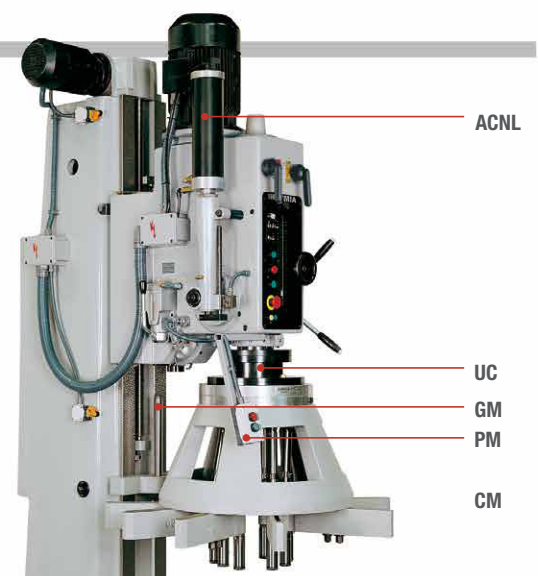
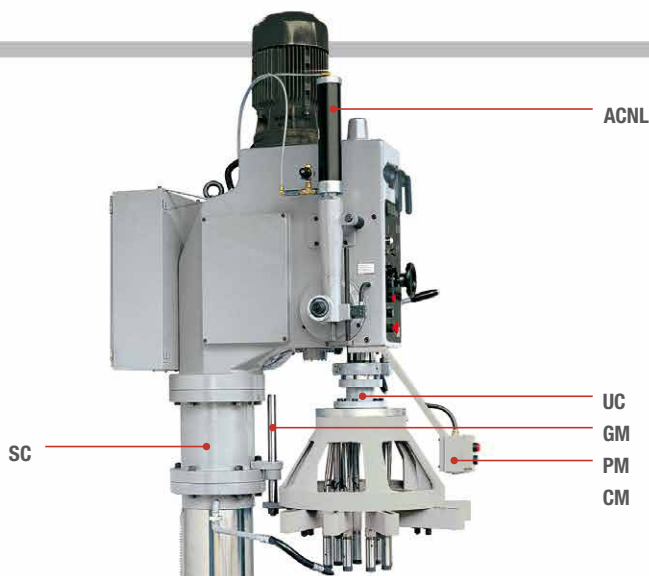

An ample fixed work table is often interesting because:

- It offers greater convenience for the positioning of the necessary parts and elements.
- Bulky or heavy pieces can be secured to the work table.

For these cases we offer our multiple drill head, machines whose construction has one overriding rule: **Flexibility**.

As well as for bulky or heavy pieces, these assemblies are very interesting for jobs in big batches where the piece must receive more than one operation as it moves from one machine head to another, receiving each operation in turn. Naturally, each machine head can be equipped differently according to the function of the operation (automatic drilling cycle, automatic tapping cycle, spotfacing, etc.)

In **CLAUSING/IBERDRILL** we offer you an endless number of combinations so that you can set up the machine to match your needs exactly. Tables of different widths and/or lengths can be combined with one, two, three... up to six machines heads. Detailed information on the different sizes of table and number of machine heads can be found on pages 29-31.



## SERIES

**K**

**T**

**Z**

**Z**

**X**

**X**

**A**

**B**

**C**

**A**

**B**



18/25



25



32



34/40



32



34/40



40



40



40/50



50



50

Drill with large fixed table and rise and falling head

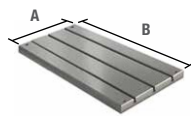

15.35" x 20.47"  
(390mm x 520mm)

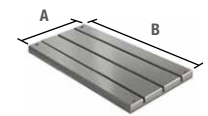

23.62" x 23.62"  
(600mm x 600mm)

Drill with extra large fixed table and rise and falling head

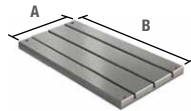

15.34" x 40.94"  
(390 x 1040mm)

15.34" x 61.42"  
(390 x 1560mm)

15.34" x 81.89"  
(390 x 2080mm)

15.34" x 102.36"  
(390 x 2600mm)

15.34" x 122.83"  
(390 x 3120mm)

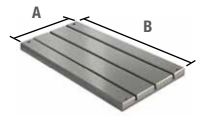

23.62" x 47.24"  
(600 x 1200mm)

23.62" x 78.74"  
(600 x 2000mm)

23.62" x 105.51"  
(600 x 2680mm)

23.62" x 129.13"  
(600 x 3280mm)

23.62" x 152.76"  
(600 x 3880mm)

Drill heads  
2 to 6

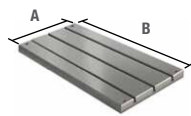

15.34" x 40.94"  
(390 x 1040mm)

15.34" x 61.42"  
(390 x 1560mm)

15.34" x 81.89"  
(390 x 2080mm)

15.34" x 102.36"  
(390 x 2600mm)

15.34" x 122.83"  
(390 x 3120mm)

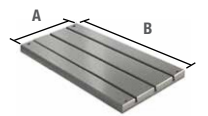

23.62" x 47.24"  
(600 x 1200mm)

23.62" x 78.74"  
(600 x 2000mm)

23.62" x 105.51"  
(600 x 2680mm)

23.62" x 129.13"  
(600 x 3280mm)

23.62" x 152.76"  
(600 x 3880mm)

These assemblies are extremely interesting in jobs of long production series where the piece undergoes more than one operation, moving from one machine head to another, receiving each operation in turn. Naturally, each machine head can be equipped differently according to the function of the operation (automatic drilling cycle, automatic tapping cycle, spotfacing, etc.). In many cases, these solutions are much more productive than machines such as machining centres and at a much lower cost.





*BP50 with extra large table of 400 x 1500 mm for the drilling of rods using a multi-spindle drilling head arranged in a line.*

## AVAILABLE TABLES

### BP50

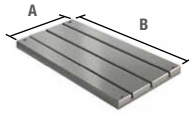

23.62" x 31.50"  
(600 x 800mm)

23.62" x 55.12"  
(600 x 1400mm)

23.62" x 81.89"  
(600 x 2080mm)

23.62" x 105.51"  
(600 x 2680mm)



*4BP50 multiple drill head with 23.62" x 105.51"*

## K SERIES

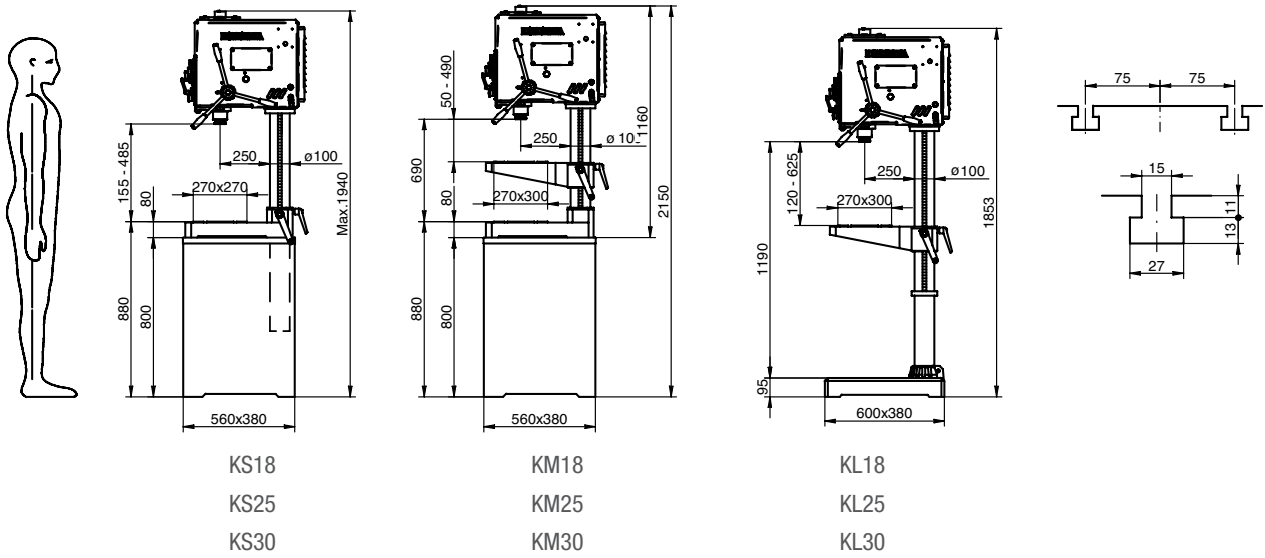

## T SERIES

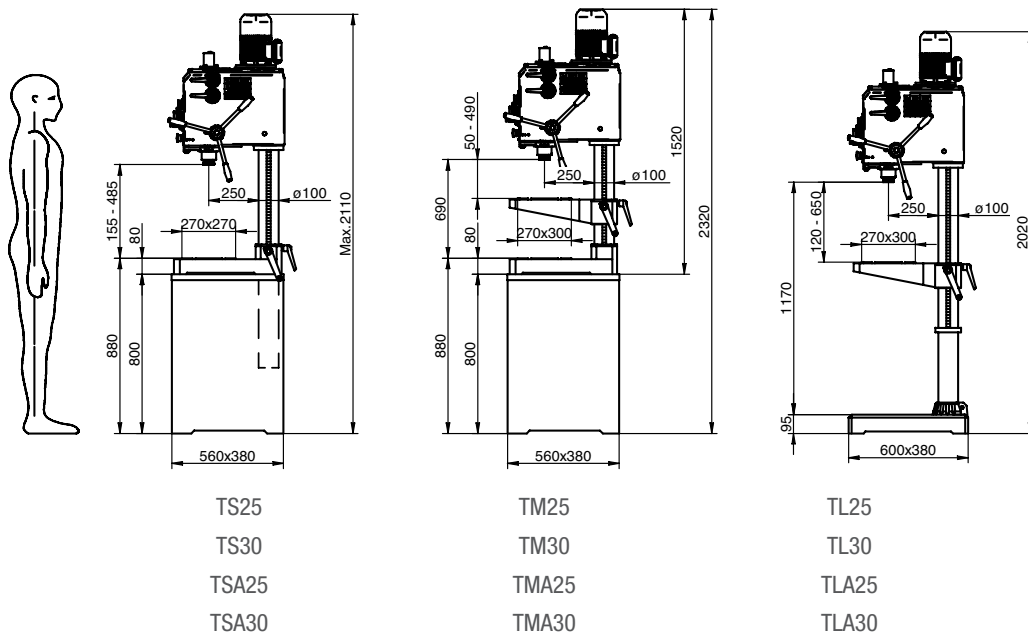



## Z SERIES

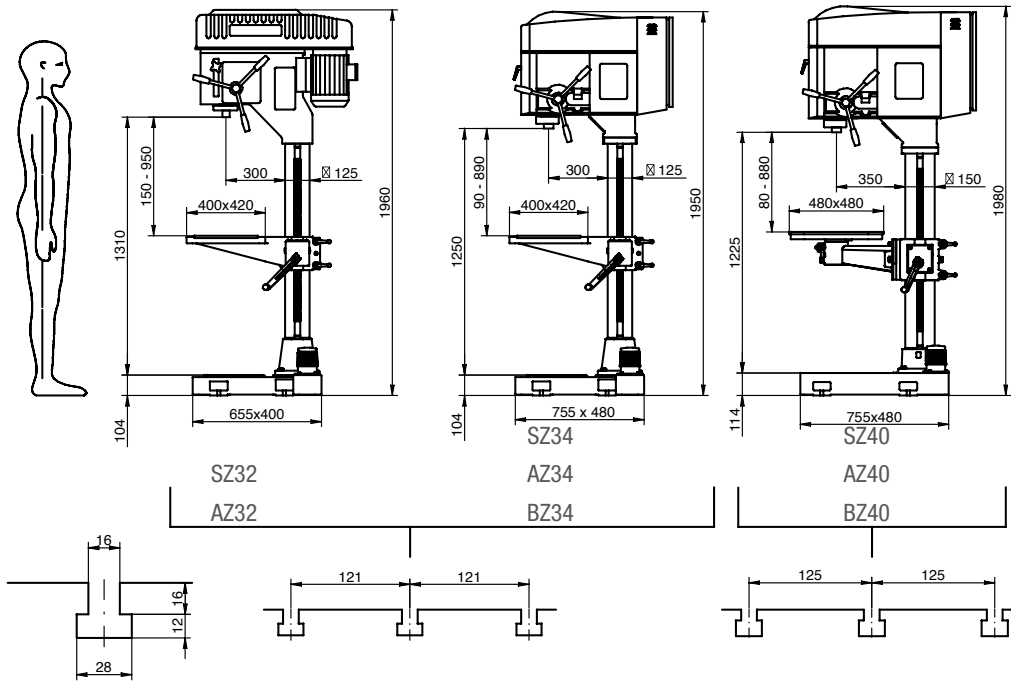

## X SERIES

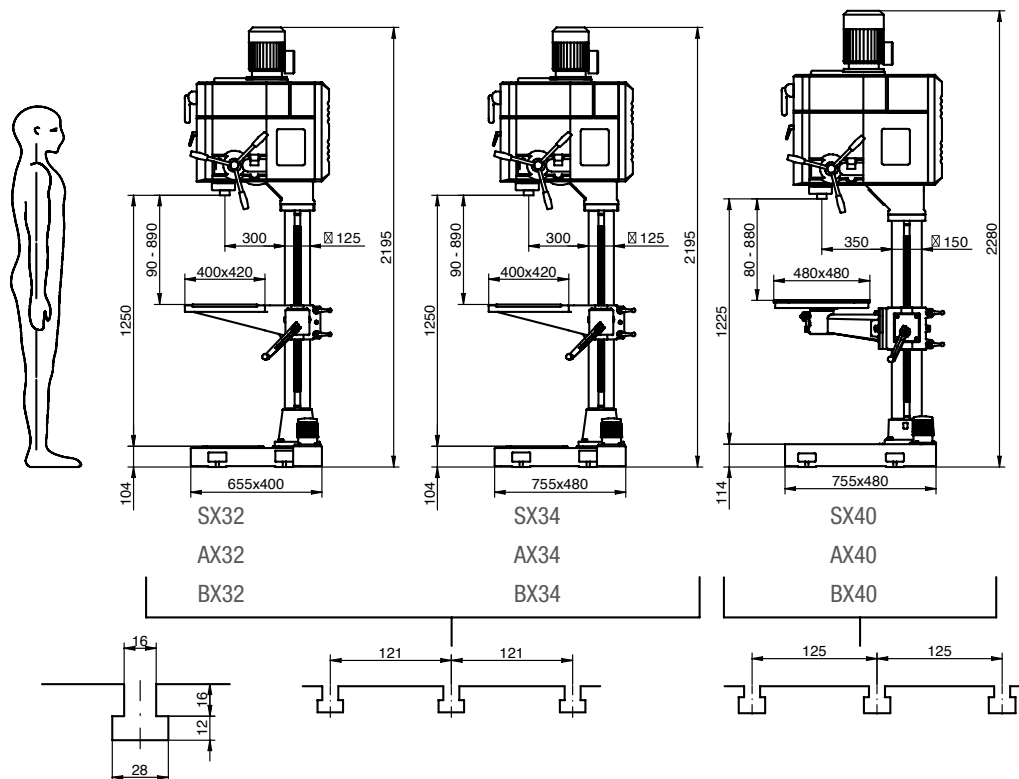

## A&B SERIES

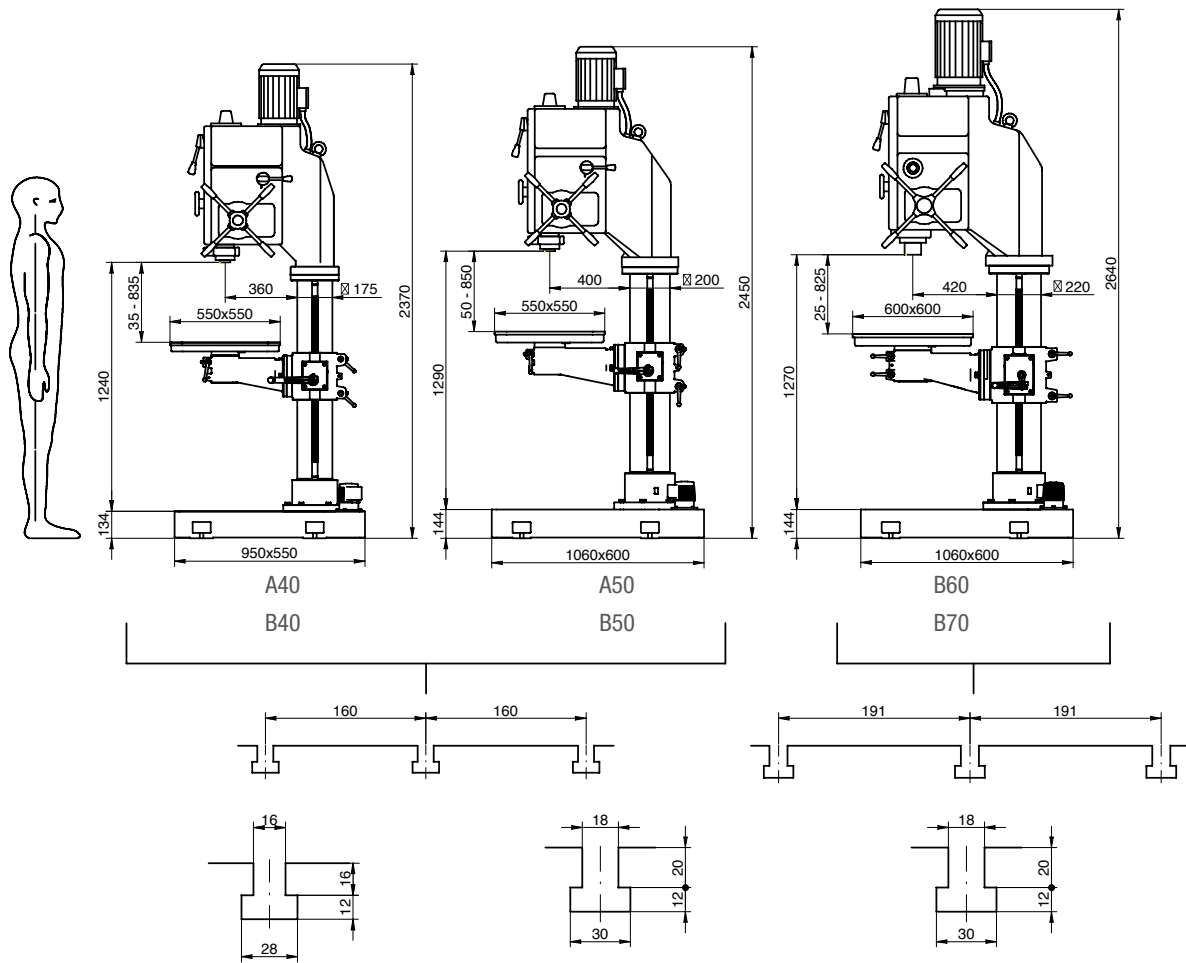

## C SERIES

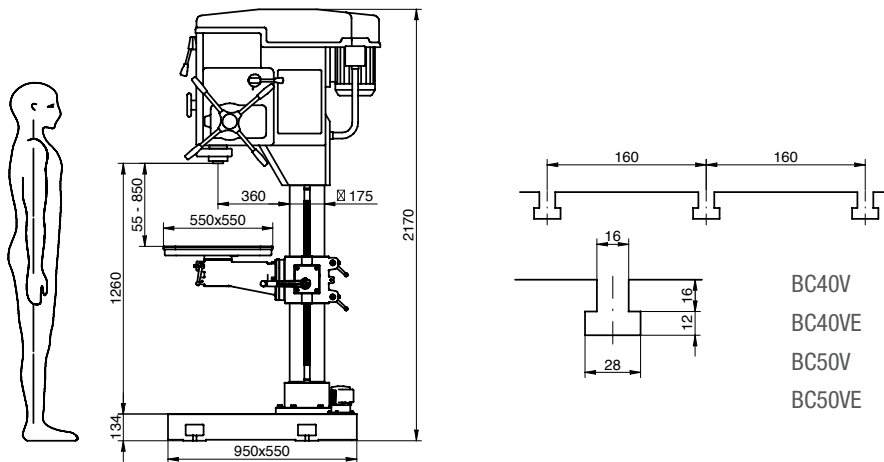

## F SERIES

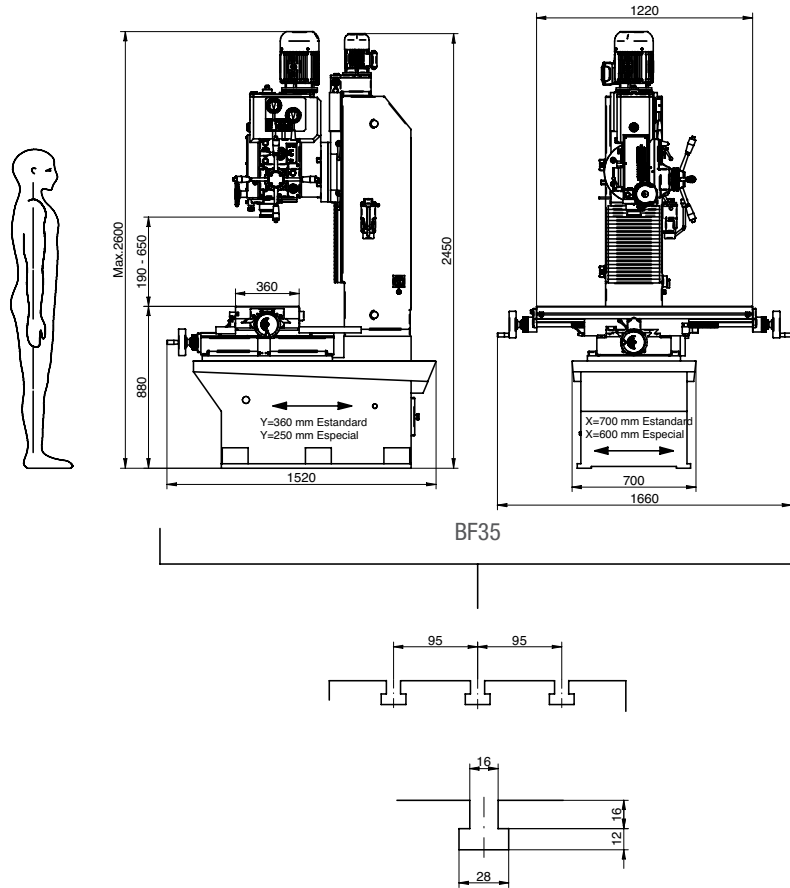

## P SERIES

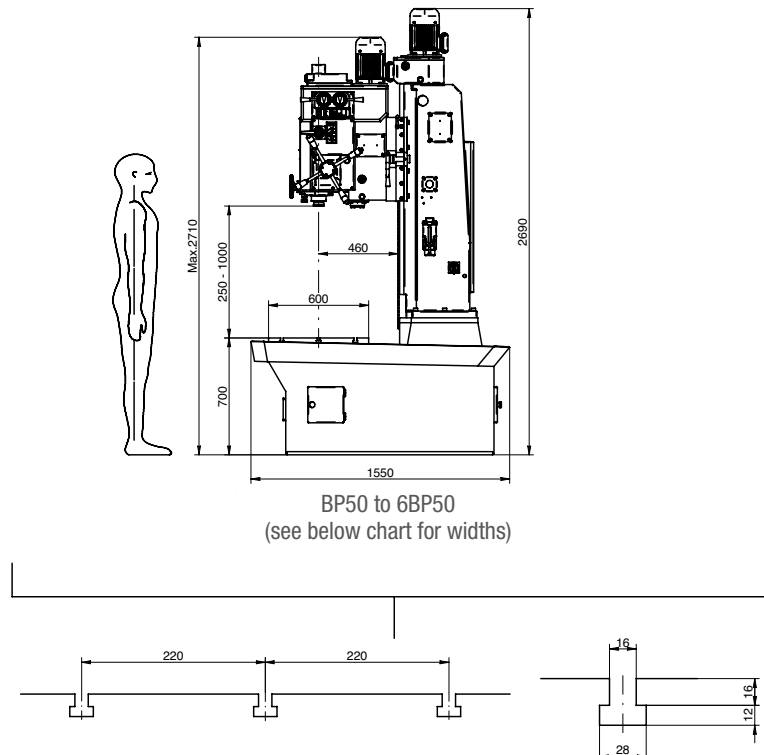

## K SERIES

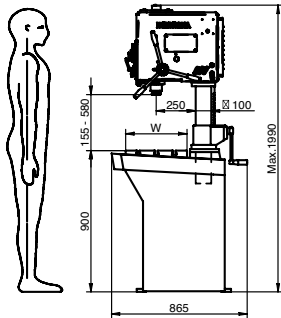

**1KS18 to 6KS18**  
**1KS25 to 6KS25**  
 (see below for widths)

## T SERIES

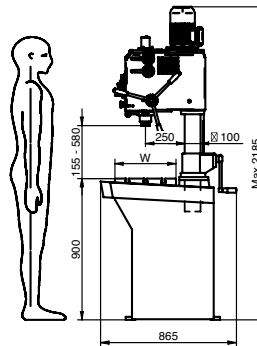

**1TS25 to 6TS25**  
 (see below for widths)

## Z SERIES

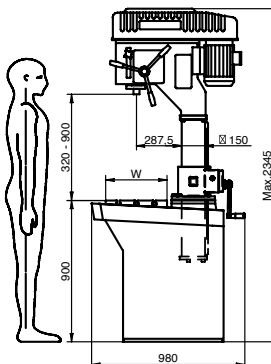

**1SZ32 to 6SZ32**  
**1AZ32 to 6AZ32**  
 (see below for widths)

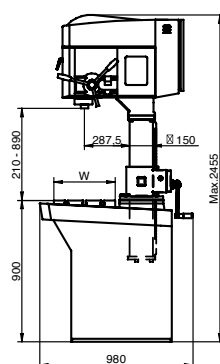

**1SZ34 to 6SZ34**  
**1AZ34 to 6AZ34**  
**1BZ34 to 6BZ34**  
 (see below for widths)

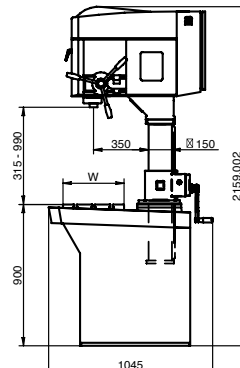

**1SZ40 to 6SZ40**  
**1AZ40 to 6AZ40**  
**1BZ40 to 6BZ40**  
 (see below for widths)

## X SERIES

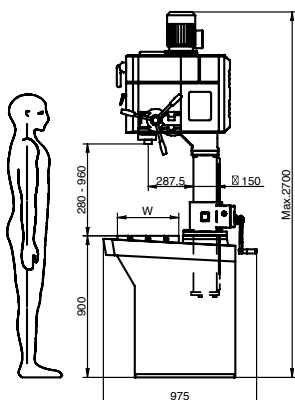

**1SX32 to 6SX32**  
**1AX32 to 6AX32**  
 (see below for widths)

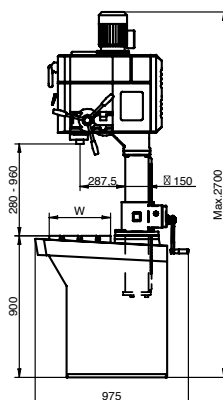

**1SX34 to 6SX34**  
**1AX34 to 6AX34**  
**1BX34 to 6BX34**  
 (see below for widths)

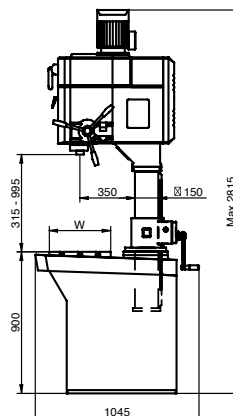

**1SX40 to 6SX40**  
**1AX40 to 6AX40**  
**1BX40 to 6BX40**  
 (see below for widths)

## C SERIES

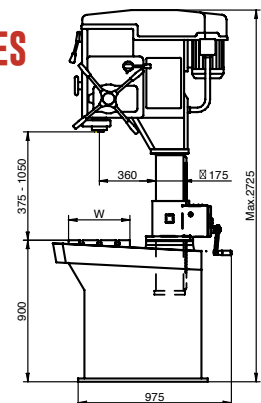

**1BC40 to 6BC40**  
**1BC40VE to 6BC40VE**  
**1BC50 to 6BC50**  
**1BC50VE to 6BC50VE**  
 (see below for widths)

## A&B SERIES

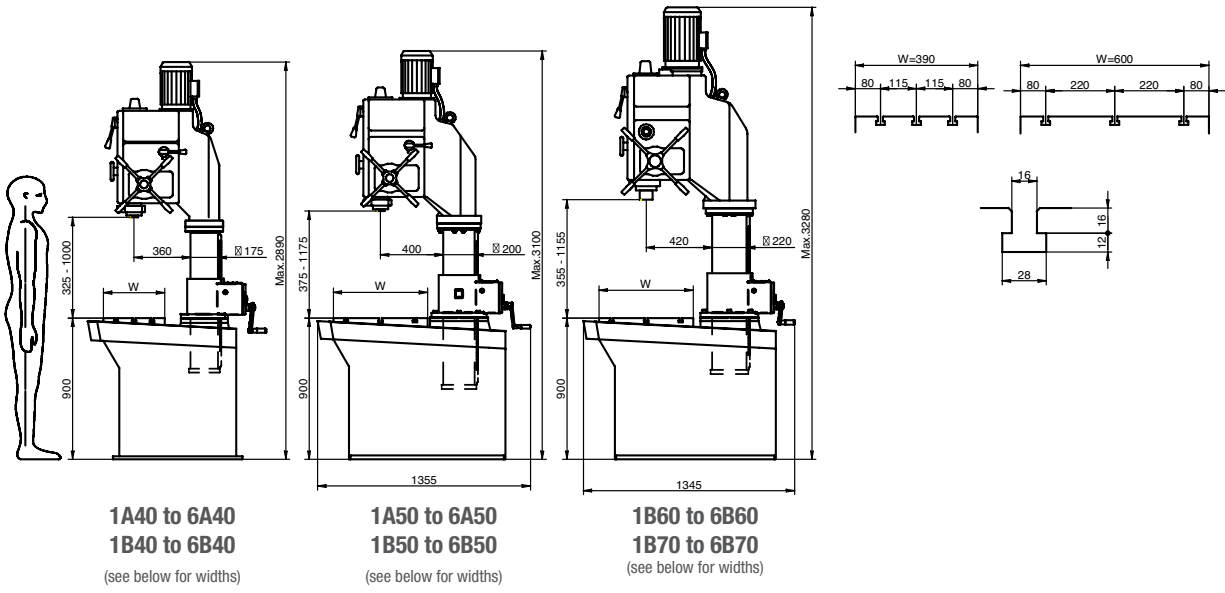

## WIDTH DIMENSIONS MULTIPLE HEAD MACHINES

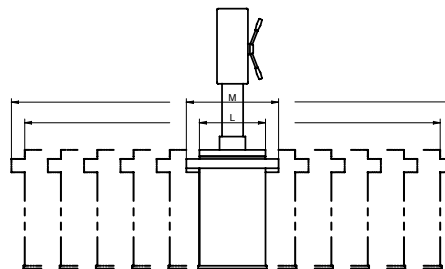
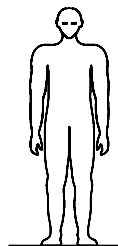

MODEL			W (mm)	L (mm)	M (mm)
1A50 1B50	1B60	1B70	23.62" (600)	23.62" (600)	31.50" (600)

MODEL W/LARGE FIXED TABLE SERIES						W (mm)	L (mm)	M (mm)
1KS18 1KS25	1TS25	1SZ32 1AZ32V 1SX32 1AX32	1SZ34/40 1AZ34/40 1BZ34/40	1A40 1B40		15.35" (390)	20.47" (520)	26.77" (680)

MODEL			W (mm)	L (mm)	M (mm)
1A50 1B50	1B60	1B70	23.62" (600)	47.24" (1200)	55.12" (1400)
			23.62" (600)	78.74" (2000)	86.61" (2200)
			23.62" (600)	105.51" (2680)	113.39" (2880)
			23.62" (600)	129.13" (3280)	137" (3480)
			23.62" (600)	152.76" (3880)	160.63" (4080)

MODEL W/EXTRA LARGE FIXED TABLE SERIES						W (mm)	L (mm)	M (mm)
1KS18 1KS25 1KS18 1KS25	1TS25	1SZ32 1AZ32V 1SX32 1AX32	1SZ34/40 1AZ34/40 1BZ34/40	1SX34/40 1AX34/40 1BX34/40	1A40 1B40	15.35" (390)	40.94" (1040)	47.24" (1200)
						15.35" (390)	61.42" (1560)	67.72" (1720)
						15.35" (390)	81.89" (2080)	88.19" (2240)
						15.35" (390)	102.36" (2600)	108.66" (2760)
						15.35" (390)	122.83" (3120)	129.13" (3280)

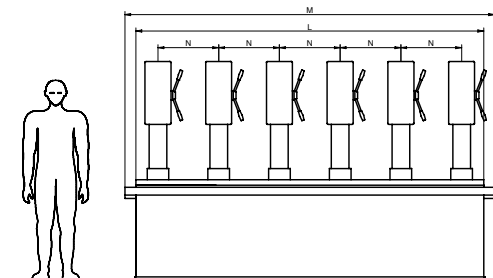

MODEL		W (mm)	L (mm)	M (mm)	N (mm)
2A50 2B50	2B60 2B70	23.62" (600)	47.24" (1200)	55.12" (1400)	27.56" (700)
3A50 3B50	3B60 3B70	23.62" (600)	78.74" (2000)	86.61" (2200)	27.56" (700)
4A50 4B50	4B60 4B70	23.62" (600)	105.51" (2680)	113.39" (2880)	27.56" (700)
5A50 5B50	5B60 5B70	23.62" (600)	122.83" (3120)	130.71" (3320)	27.56" (700)
6A50 6B50	6B60 6B70	23.62" (600)	146.46" (3720)	154.33" (3920)	27.56" (700)

MODEL							W (mm)	L (mm)	M (mm)	N (mm)
2KS18 2KS25	2TS25	2SZ32 2AZ32V	2SX32 2AX32	2SZ34/40 2AZ34/40 2BZ34/40	2SX32/40 2AX32/40 2BX32/40	2A40 2B40	15.35" (390)	40.94" (1040)	47.24" (1200)	21.65" (550)
3KS18 3KS25	3TS2	3SZ32 3AZ32V	3SX32 3AX32	3SZ32/40 3AZ32/40 3BZ32/40	3SX32/40 3AX32/40 3BX32/40	3A40 3B40	15.35" (390)	61.42" (1560)	67.72" (1720)	21.65" (550)
4KS18 4KS25	4TS2	4SZ32 4AZ32V	4SX32 4AX32	4SZ32/40 4AZ32/40 4BZ32/40	4SX32/40 4AX32/40 4BX32/40	4A40 4B40	15.35" (390)	81.89" (2080)	88.19" (2240)	21.65" (550)
5KS18 5KS25	5TS2	5SZ32 5AZ32V	5SX32 5AX32	5SZ32/40 5AZ32/40 5BZ32/40	5SX32/40 5AX32/40 5BX32/40	5A40 5B40	15.35" (390)	102.36" (2600)	108.66" (2760)	21.65" (550)
6KS18 6KS25	6TS2	6SZ32 6AZ32V	6SX32 6AX32	6SZ32/40 6AZ32/40 6BZ32/40	6SX32/40 6AX32/40 6BX32/40	6A40 6B40	15.35" (390)	122.83" (3120)	129.13" (3280)	21.65" (550)

## P SERIES

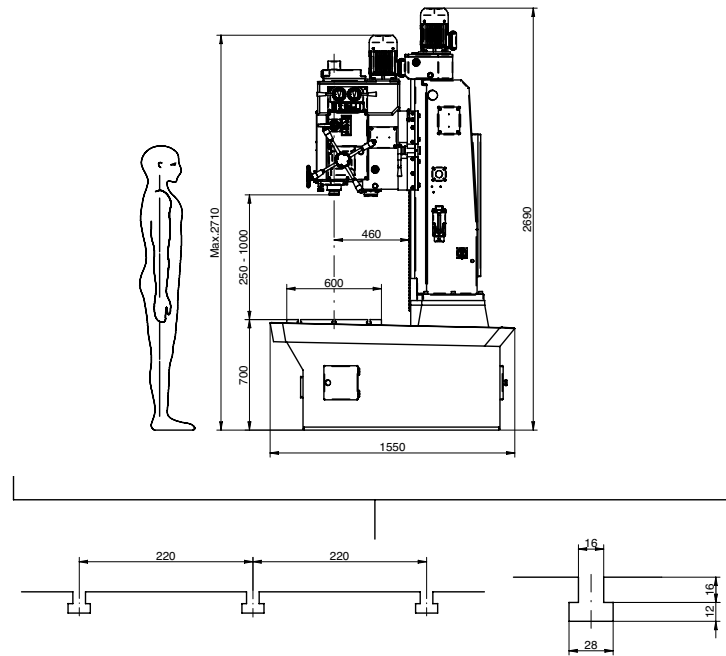

### Prismatic Column

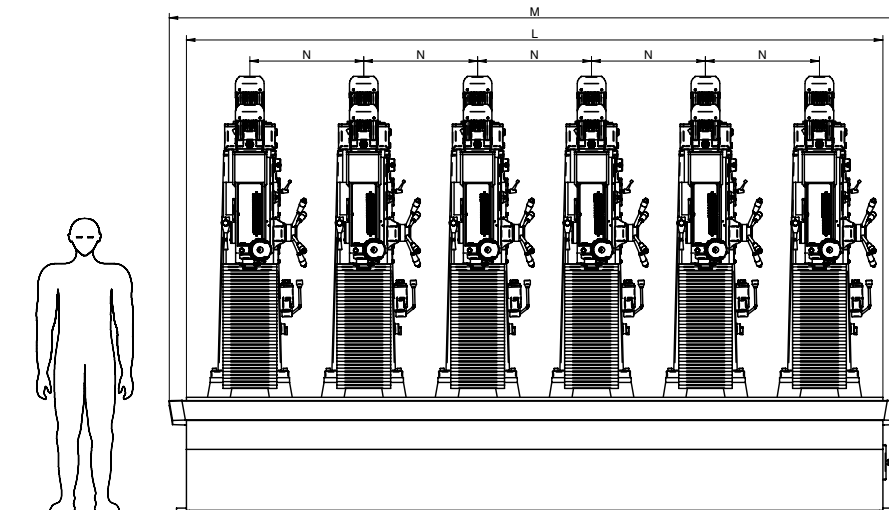

MODEL	L (mm)	M (mm)	N (mm)
BP50	31.50" (800)	39.76" (1010)	27.56" (700)
2BP50	55.12" (1400)	63.39" (1610)	27.56" (700)
3BP50	81.89" (2080)	90.16" (2290)	27.56" (700)
4BP50	105.51" (2680)	113.78" (2890)	27.56" (700)
5BP50	137" (3480)	145.28" (3690)	27.56" (700)
6BP50	160.63" (4080)	168.90" (4290)	27.56" (700)

Your Single Source for Machine Tools

### Clausing Precision Drills

- Clausing Belt-drive Drills
- Clausing Geared-head Drills
- Clausing Radial Drills

### Clausing Precision Mills

- Clausing Bed Mills
- Clausing CNC Bed Mills
- Clausing Knee Mills
- Clausing EVS Knee Mills
- Clausing CNC Knee Mills
- Clausing Universal Mills

### Clausing Precision Grinders

- Clausing Manual Grinders
- Clausing 2 Axes Hydraulic Grinders
- Clausing 3 Axes Hydraulic Grinders
- Clausing ASDIII Automatic Grinders
- Clausing OD/ID Grinders

### Clausing Precision Cutting Machines

- Clausing/Kalamazoo Horizontal Bandsaws
- Clausing/Kalamazoo Vertical Bandsaws
- Clausing/Kalamazoo Tilt Frame Miter Bandsaws
- Clausing/Kalamazoo Cold Saws

### Clausing Precision Lathes

- Clausing/Colchester Geared Head Lathes
- Clausing/Colchester Professional V.S. Lathes
- Clausing/Colchester MAGNUM V.S. Lathes
- Clausing C Series Lathes
- Clausing Large Swing Standard Lathes
- Clausing Large Swing CNC Lathes
- Clausing Precision Toolroom Lathes



For detailed catalogs of the full line of Clausing Machine Tools visit our Web Site:

[www.clausing-industrial.com](http://www.clausing-industrial.com)

Fax: 269-345-5945 or e-mail us and request an electronic (pdf) catalog at:

[info@clausing-industrial.com](mailto:info@clausing-industrial.com)

*Your Authorized Clausing Precision Machine Tools Distributor*

