



## RADIAL DRILLS

A Line of Precision Heavy-Duty,  
Large Capacity Radial Drills:

- Drilling Capacity up to 3.15" in Steel 3.94" in Cast Iron
- Tapping Capacity up to 2.56" in Steel 2.95" in Cast Iron

## CL720A



### Dimensions

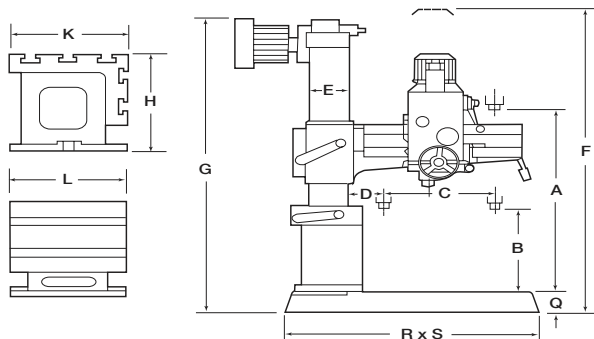

### Capacities

MODEL	CL720A
<b>CAPACITY</b>	
Drilling In Steel	1.26" (32mm)
In Cast Iron	2" (50mm)
Tapping In Steel	1" (25mm)
In Cast Iron	1.26" (32mm)

### Features and Standard Equipment

- CE Electrics (non-certified), Spindle Guard with Limit Switch, Lockable Disconnect, Safety Door
- High speed gears are made of Nickel-Chrome Steel and are heat-treated and ground for durability
- Powerful 2 Hp spindle drive motor for heavy-duty cutting
- Extra auxiliary dial for spindle feed depth indication, allows review of spindle feed depth, .0394" to 7.874"
- Special spindle balance mechanism, superior to traditional balance mechanism and extends Balance
- Spring life
- Coolant system
- Low volt and overload protection
- 230/3/60 volt standard (other voltages may require a transformer or special order)
- Tool kit and manuals

### Specifications

MODEL	CL720A
<b>WORKING AREA</b>	
Column Sleeve Dia. (E)	8.28" (210mm)
Column Face to Spindle Center Maximum (D+C)	29.5" (750mm)
Minimum (D)	8.7" (220mm)
Spindle Head Travel (C)	20.8" (530mm)
Base Surface to Spindle End Maximum (A)	41.7" (1060mm)
Minimum (B)	10.2" (260mm)
Arm Vertical Travel (A-B)	31.5" (800mm)
Arm Rotation (Right & Left)	180°
Baseplate Working Surface	35.5" x 25.3" (902x643mm)
Box Table Area Length (L)	23.6" (600mm)
Width (K)	17.5" (445mm)
Height (H)	15" (382mm)
Base Dimensions Floor Area (R x S)	49.6" x 25.2" (1260x640mm)
Height (Q)	6.5" (163mm)
<b>DRILL HEAD</b>	
Spindle Taper	4MT
Spindle Stroke	8.66" (220mm)
Quill Diameter	2.95" (75mm)
Number of Spindle Speeds	6
Spindle Speeds (rpm)	88, 154, 282, 455, 796, 1500
Number of Feeds	3
Spindle Feed Rate (in./rev.) (mm/rev.)	0.002"/0.0035"/0.006" .05mm/.09mm/.15mm
Spindle Drive Motor	2 hp (1.5 Kw)
Elevating Motor	1 hp (.75 Kw)
Coolant Pump Motor	1/8 hp (.10 Kw)
<b>DIMENSIONS AND WEIGHTS</b>	
Max. Machine Height (F)	85.4" (2170mm)
Base and Column Height (G)	72.8" (1850mm)
Shipping Dim. Length	66.1" (1680mm)
Width	32.5" (826mm)
Height	85" (2160mm)
Net Weight	2,469 lbs. (1120kg)
Shipping Weight	2,756 lbs. (1250kg)

## CL820A



### Dimensions

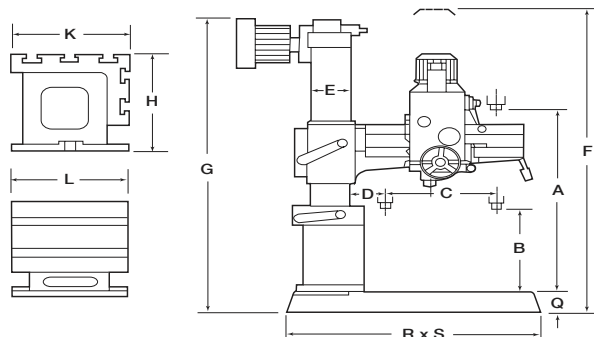

### Capacities

MODEL	CL820A
<b>CAPACITY</b>	
Drilling In Steel	1.26" (32mm)
In Cast Iron	2" (50mm)
Tapping In Steel	1" (25mm)
In Cast Iron	1.26" (32mm)

### Features and Standard Equipment

- CE Electrics (non-certified), Spindle Guard with Limit Switch, Lockable Disconnect, Safety Door
- High speed gears are made of Nickel-Chrome Steel and are heat-treated and ground for durability
- Powerful 2 Hp spindle drive motor for heavy-duty cutting
- Extra auxiliary dial for spindle feed depth indication, allows review of spindle feed depth, .0394" to 7.874"
- Special spindle balance mechanism, superior to traditional balance mechanism and extends Balance
- Spring life
- Coolant system
- Low volt and overload protection
- 230/3/60 volt standard (other voltages may require a transformer or special order)
- Tool kit and manuals

### Specifications

MODEL	CL820A
<b>WORKING AREA</b>	
Column Sleeve Dia. (E)	8.28" (210mm)
Column Face to Spindle Center Maximum (D+C)	33.5" (850mm)
Minimum (D)	8.7" (220mm)
Spindle Head Travel (C)	24.8" (630mm)
Base Surface to Spindle End Maximum (A)	47.6" (1210mm)
Minimum (B)	13.8" (350mm)
Arm Vertical Travel (A-B)	33.8" (858mm)
Arm Rotation (Right & Left)	180°
Baseplate Working Surface	35.5" x 25.3" (902x643mm)
Box Table Area Length (L)	23.6" (600mm)
Width (K)	17.5" (445mm)
Height (H)	15" (382mm)
Base Dimensions Floor Area (R x S)	49.6" x 25.2" (1260x640mm)
Height (Q)	6.5" (163mm)
<b>DRILL HEAD</b>	
Spindle Taper	4MT
Spindle Stroke	8.66" (220mm)
Quill Diameter	2.95" (75mm)
Number of Spindle Speeds	6
Spindle Speeds (rpm)	88, 154, 282, 455, 796, 1500
Number of Feeds	3
Spindle Feed Rate (in/rev.) (mm/rev.)	0.002"/0.0035"/0.006" .05mm/.09mm/.15mm
Spindle Drive Motor	2 hp (1.5 Kw)
Elevating Motor	1 hp (.75 Kw)
Coolant Pump Motor	1/8 hp (.10 Kw)
<b>DIMENSIONS AND WEIGHTS</b>	
Max. Machine Height (F)	91.3" (2320mm)
Base and Column Height (G)	79.1" (2010mm)
Shipping Dim. Length	66.1" (1680mm)
Width	32.5" (826mm)
Height	86.2" (2190mm)
Net Weight	2,645 lbs. (1200kg)
Shipping Weight	2,954 lbs. (1340kg)

## CL920A



### Dimensions

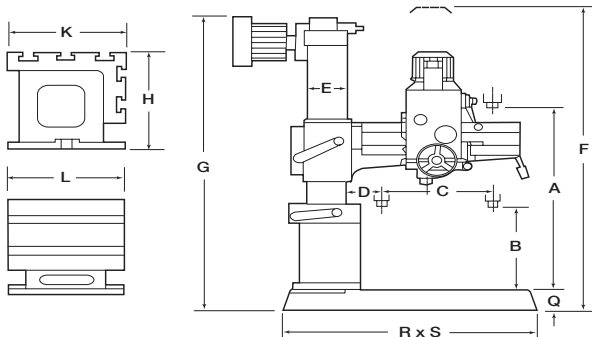

### Capacities

MODEL	CL920A
<b>CAPACITY</b>	
Drilling In Steel	1.26" (32mm)
In Cast Iron	2" (50mm)
Tapping In Steel	1" (25mm)
In Cast Iron	1.26" (32mm)

### Features and Standard Equipment

- CE Electrics (non-certified), Spindle Guard with Limit Switch, Lockable Disconnect, Safety Door
- High speed gears are made of Nickel-Chrome Steel and are heat-treated and ground for durability
- Powerful 2 Hp spindle drive motor for heavy-duty cutting
- Extra auxiliary dial for spindle feed depth indication, allows review of spindle feed depth, .0394" to 7.874"
- Special spindle balance mechanism, superior to traditional balance mechanism and extends Balance
- Spring life
- Coolant system
- Low volt and overload protection
- 230/3/60 volt standard (other voltages may require a transformer or special order)
- Tool kit and manuals

### Specifications

MODEL	CL920A
<b>WORKING AREA</b>	
Column Sleeve Dia. (E)	8.28" (210mm)
Column Face to Spindle Center Maximum (D+C)	37.4" (950mm)
Minimum (D)	8.7" (220mm)
Spindle Head Travel (C)	28.7" (730mm)
Base Surface to Spindle End Maximum (A)	47.6" (1210mm)
Minimum (B)	13.8" (350mm)
Arm Vertical Travel (A-B)	33.8" (858mm)
Arm Rotation (Right & Left)	180°
Baseplate Working Surface	35.5" x 25.3" (902x643mm)
Box Table Area Length (L)	23.6" (600mm)
Width (K)	17.5" (445mm)
Height (H)	15" (382mm)
Base Dimensions Floor Area (R x S)	49.6" x 25.2" (1260x640mm)
Height (Q)	6.5" (163mm)
<b>DRILL HEAD</b>	
Spindle Taper	4MT
Spindle Stroke	8.66" (220mm)
Quill Diameter	2.95" (75mm)
Number of Spindle Speeds	6
Spindle Speeds (rpm)	88, 154, 282, 455, 796, 1500
Number of Feeds	3
Spindle Feed Rate (in/rev.) (mm/rev.)	0.002"/0.0035"/0.006" .05mm/.09mm/.15mm
Spindle Drive Motor	2 hp (1.5 Kw)
Elevating Motor	1 hp (.75 Kw)
Coolant Pump Motor	1/8 hp (.10 Kw)
<b>DIMENSIONS AND WEIGHTS</b>	
Max. Machine Height (F)	91.3" (2320mm)
Base and Column Height (G)	79.1" (2010mm)
Shipping Dim. Length	71.1" (1806mm)
Width	32.5" (826mm)
Height	86.2" (2190mm)
Net Weight	2,756 lbs. (1250kg)
Shipping Weight	3,086 lbs. (1400kg)

## CL1100



### Dimensions

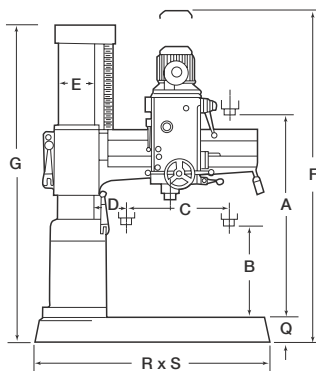
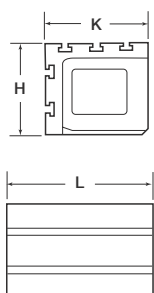

### Capacities

MODEL	CL1100
<b>CAPACITY</b>	
Drilling	
In Steel	1.65" (42mm)
In Cast Iron	2.16" (55mm)
Tapping	
In Steel	1" (25mm)
In Cast Iron	1.5" (38mm)

### Features and Standard Equipment

- CE Electrics (non-certified), Spindle Guard with Limit Switch, Lockable Disconnect, Safety Door
- High-quality cast-iron arm with heat-treated and ground slides for smooth and accurate head positioning
- The bearing bracket for gear-box is fitted with standard bearings to fit arm slide for smooth gear-box operation
- High speed gears are made of Nickel-Chrome Steel and are heat-treated and ground for durability
- Powerful 3 Hp, 2-speed, heavy-duty spindle drive motor
- Overload protection device
- The main spindle is balanced by a specially shaped spring
- Coolant system
- Low volt and overload protection
- 230/3/60 volt standard (other voltages may require a transformer or special order)
- Tool kit and manuals

### Specifications

MODEL	CL1100
<b>WORKING AREA</b>	
Column Sleeve Dia. (E)	10.24" (260mm)
Column Face to Spindle Center	
Maximum (D+C)	43.3" (1100mm)
Minimum (D)	11.0" (280mm)
Spindle Head Travel (C)	32.3" (820mm)
Base Surface to Spindle End	
Maximum (A)	50.0" (1270mm)
Minimum (B)	18.5" (470mm)
Arm Vertical Travel (A-B)	31.5" (800mm)
Arm Rotation (Right & Left)	180°
Baseplate Working Surface	48" x 29.1" (1219 x 739mm)
Box Table Area	
Length (L)	25.1" (640mm)
Width (K)	20.4" (520mm)
Height (H)	16.5" (420mm)
Base Dimensions	
Floor Area (R x S)	67.9" x 28.1" (1725 x 715mm)
Height (Q)	7.1" (180mm)
<b>DRILL HEAD</b>	
Spindle Taper	4MT
Spindle Stroke	9.05" (230mm)
Quill Diameter	3.15" (80mm)
Number of Spindle Speeds	12
Spindle Speeds (rpm)	44-1500
Number of Feeds	3
Spindle Feed Rate (in/rev.)	0.002"/0.0035"/0.006"
(mm/rev.)	.05mm/.09mm/.15mm
Spindle Drive Motor	3 hp (2.25 Kw)
Elevating Motor	1 hp (.75 Kw)
Coolant Pump Motor	1/8 hp (.10 Kw)
<b>DIMENSIONS AND WEIGHTS</b>	
Max. Machine Height (F)	99.6" (2530mm)
Base and Column Height (G)	78.7" (2000mm)
Shipping Dim.	
Length	74.0" (1880mm)
Width	34.0" (864mm)
Height	87" (2210mm)
Net Weight	3,968 lbs. (1800kg)
Shipping Weight	4,299 lbs. (1950kg)

## CL1230H



### Dimensions

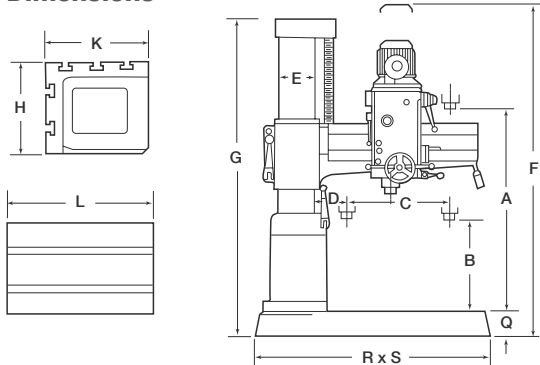

### Capacities

MODEL	CL1230H
<b>CAPACITY</b>	
Drilling	
In Steel	1.65" (42mm)
In Cast Iron	2.16" (55mm)
Tapping	
In Steel	1" (25mm)
In Cast Iron	1.38" (38mm)

### Features and Standard Equipment

- High-quality cast-iron arm with heat-treated and ground slides for smooth and accurate head positioning
- CE Electrics (non-certified), Spindle Guard with Limit Switch, Lockable Disconnect, Safety Door
- The bearing bracket for gear-box is fitted with standard bearings to fit arm slide for smooth gear-box operation
- High speed gears are made of Nickel-Chrome Steel and are heat-treated and ground for durability
- Powerful 3 Hp, 2-speed, heavy-duty spindle drive motor
- Overload protection device
- The main spindle is balanced by a specially shaped spring
- Coolant system
- Low volt and overload protection
- Equipped with hydraulic clamping. With a push of a button you can have arm unclamped then move vertically, or stop then clamp automatically
- 230/3/60 volt standard (other voltages may require a transformer or special order)
- Tool kit and manuals

### Specifications

MODEL	CL1230H
<b>WORKING AREA</b>	
Column Sleeve Dia. (E)	11.81" (300mm)
Column Face to Spindle Center	
Maximum (D+C)	46.1" (1170mm)
Minimum (D)	13.4" (340mm)
Spindle Head Travel (C)	35.0" (890mm)
Base Surface to Spindle End	
Maximum (A)	53.9" (1370mm)
Minimum (B)	19.3" (490mm)
Arm Vertical Travel (A-B)	34.6" (880mm)
Arm Rotation (Right & Left)	180°
Baseplate Working Surface	48" x 29.1" (1219 x 739mm)
Box Table Area	
Length (L)	25.1" (640mm)
Width (K)	20.4" (520mm)
Height (H)	16.5" (420mm)
Base Dimensions	
Floor Area (R x S)	67.9" x 28.1" (1725 x 715mm)
Height (Q)	7.1" (180mm)
<b>DRILL HEAD</b>	
Spindle Taper	4MT
Spindle Stroke	9.84" (250mm)
Quill Diameter	3.15" (80mm)
Number of Spindle Speeds	12
Spindle Speeds (rpm)	44-1500
Number of Feeds	3
Spindle Feed Rate (in./rev.)	0.002"/0.0035"/0.006"
(mm/rev.)	.05mm/.09mm/.15mm
Spindle Drive Motor	3 hp (2.25 Kw)
Elevating Motor	1 hp (.75 Kw)
Coolant Pump Motor	1/8 hp (.10 Kw)
<b>DIMENSIONS AND WEIGHTS</b>	
Max. Machine Height (F)	109.5" (2780mm)
Base and Column Height (G)	81.1" (2060mm)
Shipping Dim.	
Length	80.1" (2035mm)
Width	32.5" (862mm)
Height	88.2" (2240mm)
Net Weight	4,630 lbs. (2100kg)
Shipping Weight	5,071 lbs. (2300kg)

## CLC1250H



### Dimensions

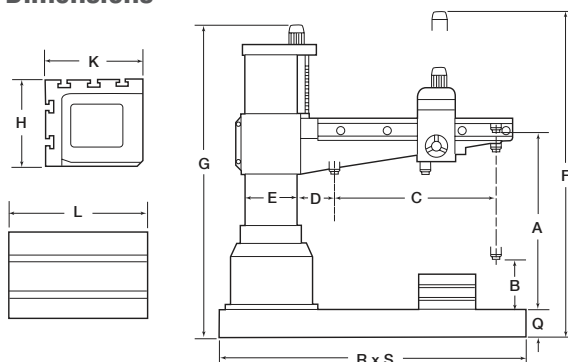

### Capacities

MODEL	CLC1250H
<b>CAPACITY</b>	
Drilling	
In Steel	1.97" (50mm)
In Cast Iron	2.36" (60mm)
Tapping	
In Steel	1.57" (40mm)
In Cast Iron	1.97" (50mm)

### Features and Standard Equipment

- CE Electrics (non-certified), Spindle Guard with Limit Switch, Lockable Disconnect, Safety Door
- Equipped with hydraulic separate clamping unit. Vertical movement of arm is coordinated by an IC timer. With a single touch on push button switch, you can have the arm unclamped then move vertically, or stop then clamp automatically. Very easy to operate, and tools will always stay at the same point after tool shifting
- Gears in gear box are cooled by oil cycled by an oil pump to minimize gear wear
- Powerful 5 Hp, 2-speed, heavy-duty spindle drive motor
- Friction type disc clutch absorbs impact force caused by vertical movement of spindle, and protects all transmission units inside gear box. With quick spindle return, the clutch will help speed-up the tapping operation
- Special arm elevating device is provided to prevent arm from falling down abruptly after years of usage
- Coolant system
- 230/3/60 volt standard (other voltages may require a transformer or special order)
- Tool kit and manuals

### Specifications

MODEL	CLC1250H
<b>WORKING AREA</b>	
Column Sleeve Dia. (E)	11.81" (300mm)
Column Face to Spindle Center	
Maximum (D+C)	49.21" (1250mm)
Minimum (D)	14.17" (360mm)
Spindle Head Travel (C)	35.04" (890mm)
Base Surface to Spindle End	
Maximum (A)	52.95" (1345mm)
Minimum (B)	17.36" (441mm)
Arm Vertical Travel (A-B)	28.1" (715mm)
Arm Rotation (Right & Left)	180°
Baseplate Working Surface	48" x 29.1" (1219 x 739mm)
Box Table Area	
Length (L)	25.1" (640mm)
Width (K)	20.4" (520mm)
Height (H)	16.5" (420mm)
Base Dimensions	
Floor Area (R x S)	70.3" x 30.9" (1785 x 785mm)
Height (Q)	7.8" (190mm)
<b>DRILL HEAD</b>	
Spindle Taper	5MT
Spindle Stroke	10.63" (270mm)
Quill Diameter	3.15" (80mm)
Number of Spindle Speeds	12
Spindle Speeds (rpm)	56-1450
Number of Feeds	3
Spindle Feed Rate (in./rev.)	0.0023"/0.004"/0.008"
(mm/rev.)	.06mm/.10mm/.20mm
Spindle Drive Motor	5 hp (3.8 Kw)
Elevating Motor	1 hp (.75 Kw)
Clamping Motor	1 hp (.75 Kw)
Coolant Pump Motor	1/8 hp (.10 Kw)
<b>DIMENSIONS AND WEIGHTS</b>	
Max. Machine Height (F)	99.6" (2530mm)
Base and Column Height (G)	78.7" (2000mm)
Shipping Dim.	
Length	74.0" (1880mm)
Width	34.0" (864mm)
Height	87" (2210mm)
Net Weight	3,968 lbs. (1800kg)
Shipping Weight	4,299 lbs. (1950kg)

## CLC1600H



Shown with Optional Tilt Table

### Dimensions

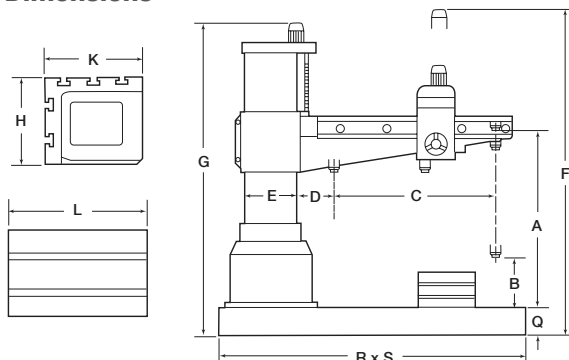

### Capacities

MODEL	CLC1600H
<b>CAPACITY</b>	
Drilling	
In Steel	1.97" (50mm)
In Cast Iron	2.36" (60mm)
Tapping	
In Steel	1.57" (40mm)
In Cast Iron	1.97" (50mm)

### Features and Standard Equipment

- CE Electrics (non-certified), Spindle Guard with Limit Switch, Lockable Disconnect, Safety Door
- Equipped with hydraulic separate clamping unit. Vertical movement of arm is coordinated by an IC timer. With a single touch on push button switch, you can have the arm unclamped then move vertically, or stop then clamp automatically. Very easy to operate, and tools will always stay at the same point after tool shifting
- Gears in gear box are cooled by oil cycled by an oil pump to minimize gear wear
- Powerful 5 Hp, 2-speed, heavy-duty spindle drive motor
- Friction type disc clutch absorbs impact force caused by vertical movement of spindle, and protects all transmission units inside gear box. With quick spindle return, the clutch will help speed-up the tapping operation
- Special arm elevating device is provided to prevent arm from falling down abruptly after years of usage
- Coolant system
- 230/3/60 volt standard (other voltages may require a transformer or special order)
- Tool kit and manuals

### Specifications

MODEL	CLC1600H
<b>WORKING AREA</b>	
Column Sleeve Dia. (E)	12.61" (320mm)
Column Face to Spindle Center	
Maximum (D+C)	63.00" (1600mm)
Minimum (D)	13.78" (350mm)
Spindle Head Travel (C)	49.21" (1250mm)
Base Surface to Spindle End	
Maximum (A)	55.90" (1420mm)
Minimum (B)	18.31" (465mm)
Arm Vertical Travel (A-B)	36.7" (932mm)
Arm Rotation (Right & Left)	180°
Baseplate Working Surface	70.9" x 40.4" (1800 x 1026mm)
Box Table Area	
Length (L)	24.8" (630mm)
Width (K)	19.7" (500mm)
Height (H)	19.7" (500mm)
Base Dimensions	
Floor Area (R x S)	100.4" x 38.2" (2550 x 970mm)
Height (Q)	7.9" (200mm)
<b>DRILL HEAD</b>	
Spindle Taper	5MT
Spindle Stroke	10.63" (270mm)
Quill Diameter	3.15" (80mm)
Number of Spindle Speeds	12
Spindle Speeds (rpm)	56-1450
Number of Feeds	3
Spindle Feed Rate (in/rev.)	0.0023"/0.004"/0.008"
(mm/rev.)	.06mm/.10mm/.20mm
Spindle Drive Motor	5 hp (3.8 Kw)
Elevating Motor	2 hp (1.5 Kw)
Clamping Motor	1 hp (.75 Kw)
Coolant Pump Motor	1/8 hp (.10 Kw)
<b>DIMENSIONS AND WEIGHTS</b>	
Max. Machine Height (F)	108.7" (2760mm)
Base and Column Height (G)	86.1" (2186mm)
Shipping Dim.	
Length	105.2" (2670mm)
Width	44.1" (1120mm)
Height	94.9" (2410mm)
Net Weight	7,275 lbs. (3300kg)
Shipping Weight	8,378 lbs. (3800kg)



## CL1600H



Shown with Optional Tilt Table

### Dimensions

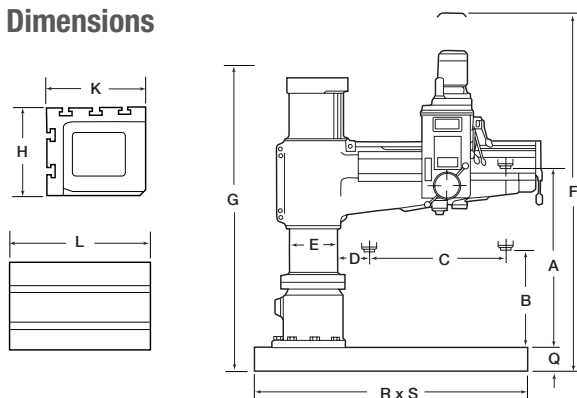

### Capacities

MODEL	CL1600H
<b>CAPACITY</b>	
Drilling	
In Steel	2.6" (65mm)
In Cast Iron	2.75" (70mm)
Tapping	
In Steel	1.97" (50mm)
In Cast Iron	2.36" (60mm)

### Features and Standard Equipment

- CE Electrics (non-certified), Spindle Guard with Limit Switch, Lockable Disconnect, Safety Door
- Equipped with hydraulic separate clamping unit. Vertical movement of arm is coordinated by an IC timer. With a single touch on push button switch, you can have the arm unclamped then move vertically, or stop then clamp automatically. Very easy to operate, and tools will always stay at the same point after tool shifting
- Gears in gear box are cooled by oil cycled by an oil pump to minimize gear wear
- Friction type disc clutch absorbs impact force caused by vertical movement of spindle, and protects all transmission units inside gear box. With quick spindle return, the clutch will help speed-up the tapping operation
- Special automatic tool eject device is supplied to allow you to change tools quickly. (No drifter is required)
- Special arm elevating device is provided to prevent arm from falling down abruptly after years of usage
- Coolant system
- 230/3/60 volt standard (other voltages may require a transformer or special order)
- Tool kit and manuals

### Specifications

MODEL	CL1600H
<b>WORKING AREA</b>	
Column Sleeve Dia. (E)	17" (432mm)
Column Face to Spindle Center	
Maximum (D+C)	62.2" (1580mm)
Minimum (D)	17.3" (440mm)
Spindle Head Travel (C)	44.9" (1140mm)
Base Surface to Spindle End	
Maximum (A)	63" (1600mm)
Minimum (B)	15" (380mm)
Arm Vertical Travel (A-B)	48" (1220mm)
Arm Rotation (Right & Left)	180°
Baseplate Working Surface	70.9" x 40.4" (1800 x 1026mm)
Box Table Area	
Length (L)	27.6" (700mm)
Width (K)	19.7" (500mm)
Height (H)	15.9" (405mm)
Base Dimensions	
Floor Area (R x S)	97.6" x 41.3" (2480 x 1050mm)
Height (Q)	8.26" (210mm)
<b>DRILL HEAD</b>	
Spindle Taper	5MT
Spindle Stroke	14.6" (370mm)
Quill Diameter	3.94" (100mm)
Number of Spindle Speeds	12
Spindle Speeds (rpm)	36-1890
Number of Feeds	6
Spindle Feed Rate (in/rev.)	0.003"(.07mm)–0.038"(.96mm)
Spindle Drive Motor	7.5 hp (5.6 Kw)
Elevating Motor	2 hp (1.5 Kw)
Clamping Motor	1 hp (.75 Kw)
Coolant Pump Motor	1/8 hp (.10 Kw)
<b>DIMENSIONS AND WEIGHTS</b>	
Max. Machine Height (F)	124.8" (3170mm)
Base and Column Height (G)	104.7 (2660mm)
Shipping Dim.	
Length	112.2" (2850mm)
Width	55.1" (1400mm)
Height	115.7" (2940mm)
Net Weight	10,141 lbs. (4600kg)
Shipping Weight	11,245 lbs. (5100kg)

## CL2000H



### Dimensions

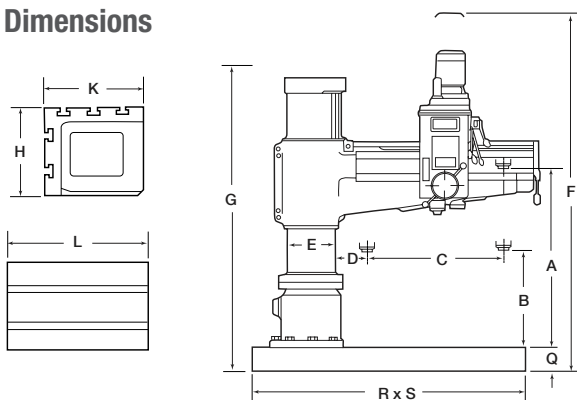

### Capacities

MODEL	CL2000H
<b>CAPACITY</b>	
Drilling	
In Steel	2.6" (65mm)
In Cast Iron	2.75" (70mm)
Tapping	
In Steel	1.97" (50mm)
In Cast Iron	2.36" (60mm)

### Features and Standard Equipment

- CE Electrics (non-certified), Spindle Guard with Limit Switch, Lockable Disconnect, Safety Door
- Equipped with hydraulic separate clamping unit. Vertical movement of arm is coordinated by an IC timer. With a single touch on push button switch, you can have the arm unclamped then move vertically, or stop then clamp automatically. Very easy to operate, and tools will always stay at the same point after tool shifting
- Gears in gear box are cooled by oil cycled by an oil pump to minimize gear wear
- Friction type disc clutch absorbs impact force caused by vertical movement of spindle, and protects all transmission units inside gear box. With quick spindle return, the clutch will help speed-up the tapping operation
- Special arm elevating device is provided to prevent arm from falling down abruptly after years of usage
- Coolant system
- 230/3/60 volt standard (other voltages may require a transformer or special order)
- Tool kit and manuals

### Specifications

MODEL	CL2000H
<b>WORKING AREA</b>	
Column Sleeve Dia. (E)	17" (432mm)
Column Face to Spindle Center	
Maximum (D+C)	78.7" (2000mm)
Minimum (D)	19.3" (490mm)
Spindle Head Travel (C)	59.4" (1510mm)
Base Surface to Spindle End	
Maximum (A)	74.8" (1900mm)
Minimum (B)	19.7" (500mm)
Arm Vertical Travel (A-B)	55.1" (1400mm)
Arm Rotation (Right & Left)	180°
Baseplate Working Surface	62.7" (1593mm) x 31.6" (804mm)
Box Table Area	
Length (L)	39.3" (1000mm)
Width (K)	31.5" (800mm)
Height (H)	19.7" (500mm)
Base Dimensions	
Floor Area (R x S)	114.5" x 43.3" (2908 x 1102mm)
Height (Q)	9.84" (250mm)
<b>DRILL HEAD</b>	
Spindle Taper	5MT
Spindle Stroke	14.6" (370mm)
Quill Diameter	3.94" (100mm)
Number of Spindle Speeds	12
Spindle Speeds (rpm)	35–1890
Number of Feeds	6
Spindle Feed Rate (in/rev.) (mm/rev.)	0.003"(.07mm)–0.038"(.96mm)
Spindle Drive Motor	7.5 hp (5.6 Kw)
Elevating Motor	3 hp (2.25 Kw)
Clamping Motor	1 hp (.75 Kw)
Coolant Pump Motor	1/8 hp (.10 Kw)
<b>DIMENSIONS AND WEIGHTS</b>	
Max. Machine Height (F)	124.8" (3470mm)
Base and Column Height (G)	116.5" (2960mm)
Shipping Dim.	
Length	122.2" (3105mm)
Width	55.1" (1400mm)
Height	130" (3300mm)
Net Weight	12,346 lbs. (5600kg)
Shipping Weight	14,550 lbs. (6600kg)

## CLC2500



### Features and Standard Equipment

- CE Electrics (non-certified), Spindle Guard with Limit Switch, Lockable Disconnect, Safety Door
- Equipped with hydraulic separate clamping unit. Vertical movement of arm is coordinated by an IC timer. With a single touch on push button switch, you can have the arm unclamped then move vertically, or stop then clamp automatically. Very easy to operate, and tools will always stay at the same point after tool shifting
- Gears in gear box are cooled by oil cycled by an oil pump to minimize gear wear
- Friction type disc clutch absorbs impact force caused by vertical movement of spindle, and protects all transmission units inside gear box. With quick spindle return, the clutch will help speed-up the tapping operation
- Special arm elevating device is provided to prevent arm from falling down abruptly after.
- Coolant system
- 230/3/60 volt standard (other voltages may require a transformer or special order)
- Tool kit and manuals

### Specifications

MODEL	CLC2500
<b>WORKING AREA</b>	
Column Sleeve Dia. (E)	21.65" (550mm)
Column Face to Spindle Center Maximum (D+C)	98.4" (2500mm)
Minimum (D)	19.7" (500mm)
Spindle Head Travel (C)	78.7" (2000mm)
Base Surface to Spindle End Maximum (A)	78.7" (2000mm)
Minimum (B)	21.6" (550mm)
Arm Vertical Travel (A-B)	57.1" (1450mm)
Arm Rotation (Right & Left)	180°
Baseplate Working Surface	86.8" x 43.4" (2205 x 1102mm)
Box Table Area Length (L)	39.4" (1000mm)
Width (K)	31.5" (800mm)
Height (H)	22" (560mm)
Base Dimensions Floor Area (R x S)	138.6" x 55.1" (3520 x 1400mm)
Height (Q)	12.6" (320mm)
<b>DRILL HEAD</b>	
Spindle Taper	6MT
Spindle Stroke	17.7" (450mm)
Quill Diameter	3.94" (100mm)
Number of Spindle Speeds	16
Spindle Speeds (rpm)	16-1250
Number of Feeds	16
Spindle Feed Rate (in/rev.)	0.0015"(.04mm)-0.126"(3.20mm)
Spindle Drive Motor	10 hp (7.5 Kw)
Elevating Motor	5 hp (3.6 Kw)
Clamping Motor	1 hp (.75 Kw)
Coolant Pump Motor	1/4 hp (.18 Kw)
<b>DIMENSIONS AND WEIGHTS</b>	
Max. Machine Height (F)	157" (3990mm)
Base and Column Height (G)	151.6" (3850mm)
Shipping Dim. Length	158" (4000mm)
Width	63" (1600mm)
Height	151.6" (3850mm)
Net Weight	24,250 lbs. (11000kg)
Shipping Weight	27,557 lbs. (12500kg)

### Dimensions

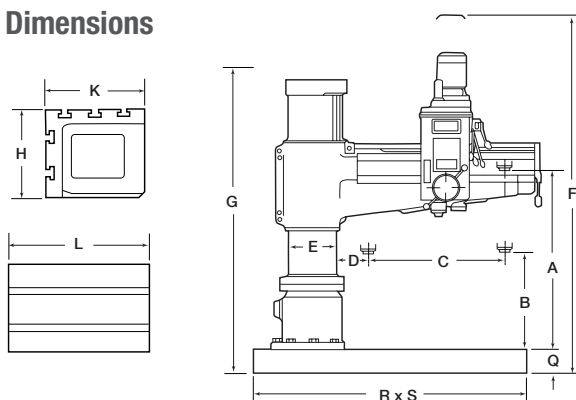

### Capacities

MODEL	CLC2500
<b>CAPACITY</b>	
Drilling In Steel	3.15" (80mm)
In Cast Iron	3.98" (100mm)
Tapping In Steel	2.56" (65mm)
In Cast Iron	2.95" (75mm)



For detailed catalogs of the full line of Clausing Machine Tools visit our Web Site:

[www.clausing-industrial.com](http://www.clausing-industrial.com)

Fax: 269-345-5945 or e-mail us and request an electronic (pdf) catalog at:

[info@clausing-industrial.com](mailto:info@clausing-industrial.com)

Your Single Source for Machine Tools

### **Clausing Precision Drills**

- Clausing Belt-drive Drills
- Clausing Geared-head Drills
- Clausing Radial Drills

### **Clausing Precision Mills**

- Clausing Bed Mills
- Clausing CNC Bed Mills
- Clausing Knee Mills
- Clausing EVS Knee Mills
- Clausing CNC Knee Mills
- Clausing Universal Mills

### **Clausing Precision Lathes**

- Clausing/Colchester Geared Head Lathes
- Clausing/Colchester Professional V.S. Lathes
- Clausing/Colchester MAGNUM V.S. Lathes
- Clausing C Series Lathes
- Clausing Large Swing Standard Lathes
- Clausing Large Swing CNC Lathes
- Clausing Precision Toolroom Lathes

### **Clausing Precision Grinders**

- Clausing Manual Grinders
- Clausing 2 Axes Hydraulic Grinders
- Clausing 3 Axes Hydraulic Grinders
- Clausing ASDIII Automatic Grinders
- Clausing OD/ID Grinders

### **Clausing Precision Cutting Machines**

- Clausing/Kalamazoo Horizontal Bandsaws
- Clausing/Kalamazoo Vertical Bandsaws
- Clausing/Kalamazoo Tilt Frame Miter Bandsaws
- Clausing/Kalamazoo Cold Saws

*Your Authorized Clausing Precision Machine Tools Distributor*

