



MULTITURN LATHES

A comprehensive line of CNC Teach lathes, perfect for many of today's CNC turning applications.

MULTITURN

This highly versatile flat bed design handles a wide range of turning applications: long shafts, bar stock, castings and with the gap removed, large diameter face plate work. Engineered for precision and maximum CNC performance with features found only on high-end CNC lathes. The Clausing MultiTurn is equipped with the latest generation FANUC /w Alpha System built into the control package with all digital control and drives or the Siemens CNC Control with Icon Key based conversational programming or Conventional ISO G-code programming. A wide choice of tooling options are available to further enhance the versatility of the machine. Quick-change tool posts and automatic indexing turrets are available to maximize output in almost any situation. The heavy-duty cast iron machine is ideal for: CNC users looking for increased versatility at a very low capital outlay, first time CNC buyers looking for programming simplicity, job shops looking for increased output, low to high production runs, and education and training facilities needing a real lathe with step-by-step simplicity.

The perfect machines for many of today's CNC turning applications!

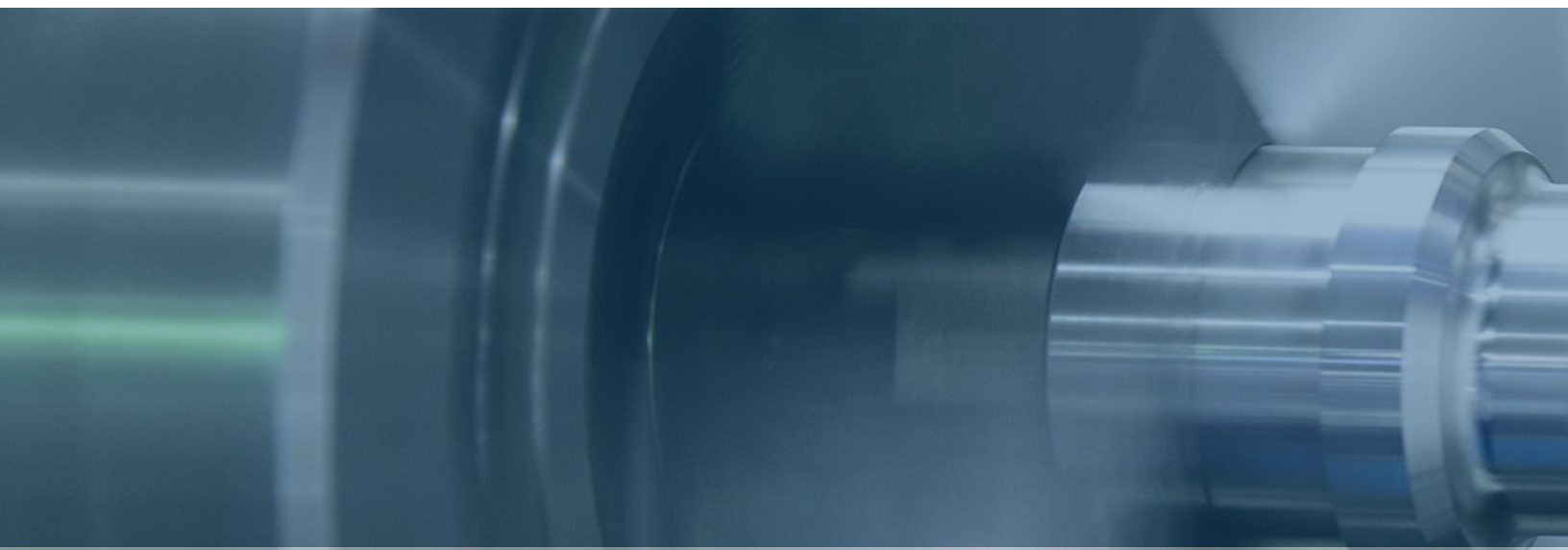

Specifications & Features of the MultiTurn Series

- Control panel rides on a rail ensuring it can be positioned conveniently for the operator
- Headstock spindle, shafts, and gears are made of high-grade alloy steel, hardened and precision ground for higher speed use with less heat and noise generation.
- Anti-friction PTFE material between saddle and bed greatly reduces friction and has superior dampening properties to reduce chatter during machine cycles.
- Heavy-duty cast iron bed ways are induction hardened over 50 Rc (5000/6000/7000) and 45 Rc (1000/2000/3000/4000)
- 'Warren' bed design provides very high torsional stiffness, eliminating bed deflection even under heavy cutting conditions.
- Extra wide bed maximizes support for saddle and cross slide assembly for smooth machining, even of large workpieces.
- Superior headstock lubrication with an external electric oil pump ensures a long life of the spindle bearings and gearing
- Automatic oil system, with low oil alarm, to maintain proper lubrication of slideways and ballscrews
- Digital AC servo drive system provides powerful and accurate axis positioning
- Variable AC spindle drive motor for exceptional range of spindle speeds
- Automatic three range headstock allows full horsepower at low RPM for more efficient machining of large components and hardened steels
- Fully enclosed, interlocking guarding to maintain a clean work environment

Machine Bed

Clausing MultiTurn's cutting-edge lathe design and construction quality begins with its unique bed design. MultiTurn beds use high quality cast iron, with a unique 'Warren' type design for maximum strength and optimum chip clearance. In addition, the MultiTurn lathe bed is mounted on cast-iron bases, to provide a solid foundation. Slideways are hardened and specifically ground to ensure high-precision, parallel operation of the lathe at all times.

Operator's Console

The operator's console is located and designed for the operator's convenience and efficiency with the cutting tool. The handwheels are installed at the ideal ergonomic height for ease of use and have the MultiTurn's popular "one-click-one-micron" rotational feel sensitivity. The complete operator's control panel moves on its own independent carriage which allows it to be moved quickly and effortlessly to the side during loading and set up.

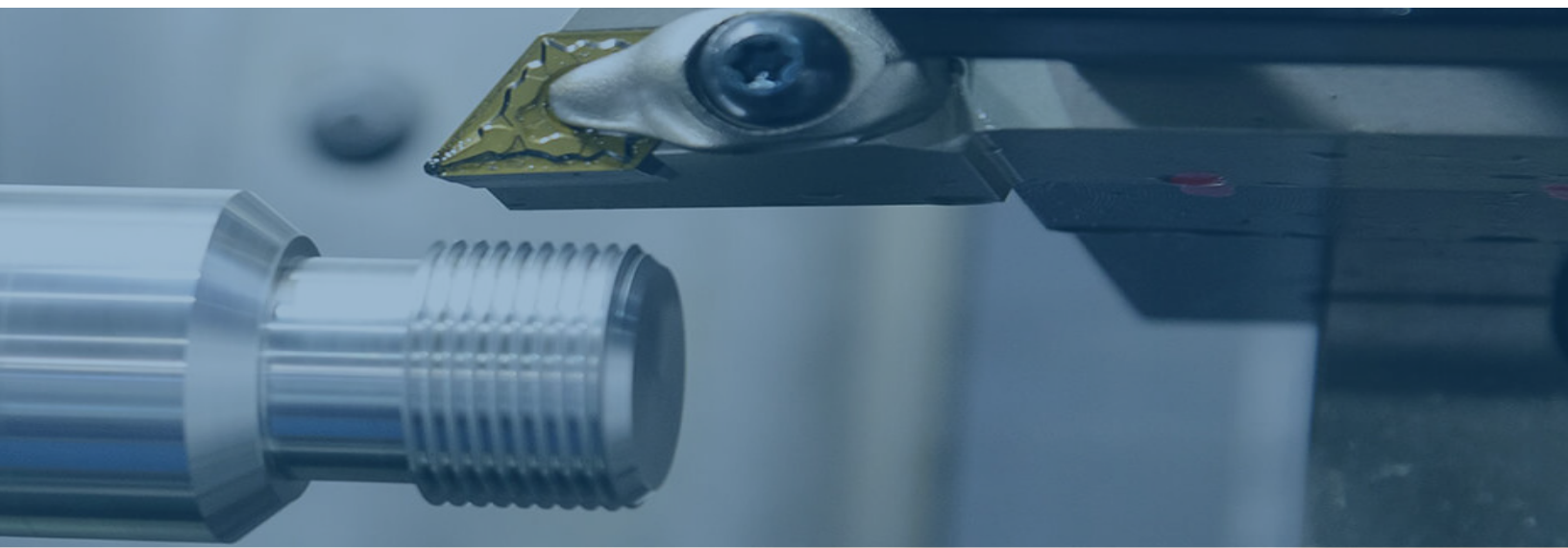

Drive Train

Into the design and development of all MultiTurn lathes goes the technical expertise of specialist from Clausing's partnered companies. Their combined research programs ensure that all new MultiTurn lathes feature the most advanced developments in spindle bearing technology and chuck design. This provides the highest possible spindle speeds and optimal chuck performance for high accuracy turning and maximum load carry capacity.

Headstock

Crucial to precision turning and component quality is the design and capability of the headstock. These lathes have top rated spindle motors for extra power and increased torque across all speed ranges. The 'bottom end' torque has been increased by over 75%, giving accurate performance even at low speeds. All Clausing MultiTurn lathes are equipped with three range headstock enabling the correct range to be automatically selected from the lathe's control system.



MULTITURN XS SERIES



FANUC CONTROL WITH ALPHA CONTROL SYSTEM

Clausing/MultiTurn XS Series:

The XS series features the Fanuc control with Colchester/Harrison enhanced 'Manual Guide i' assisted programming allows the operator to generate part programs quickly and efficiently through the use of easy-to-understand conversational style cycle prompts. The Fanuc control package comes with an all-digital control and drives offering exceptional value and reliability.

The Fanuc is one of the most user-friendly controls in the industry today and is loaded with many standard features to increase your productivity...

- Multi-repetitive Cycles G70-G76 for auto-matic finishing, roughing, drilling, threading, and grooving cycles
- Toolpath Graphics for verification of part profile
- 10.4" Color LCD Display
- Inch/metric data input
- Absolute/incremental programming in the same block
- Thread cutting leads range from 0.00001" to 1.0"
- Threading retract
- Variable lead threading
- Multiple and continuous threading
- Rigid tapping
- 2 axes linear and circular interpolation
- Constant surface speed/direct RPM programming
- Menu programming format with operator prompts
- Sequence number search
- Sequence number comparison and stop
- 128K part program memory
- Background editing
- Extended part program edit
- 64 sets of tool offsets
- Optional stop/block delete
- Run hour part counter
- Tool nose radius compensation
- Tool geometry/wear offsets
- Tool life management
- Work coordinate system G52-G59
- Automatic reference zero return G28
- Reference position return check G27
- Spindle orientation
- Machine alarm diagnostic
- Absolute encoders
- Manual pulse generator
- RS 232 interface port
- Mirror image
- Turret crash protection
- Dynamic graphic display
- Pattern data input
- Manual intervention and return
- Chuck/tailstock barrier
- Latest Fanuc Beta i series spindle and Beta i axis motor

Harrison/Colchester Manual Guide *i* for XS-Series

CNC Turning

The real strength of Manual Guide *i* is the CNC Graphical user Interface. While working in Manual Guide *i*, the Fanuc control system is creating a CNC program in the background. The conversion from conversational mode to CNC mode is instant. The programmer can work in either CNC or conversational mode or even both at the same time. Furthermore, industry standard CNC programs can be loaded into and out of the control.

Simulation and Animation

Manual Guide has a more powerful graphics package than many commercial CAD/CAM systems. After a program has been created, a simulated component can be viewed in any direction, or as a 3D model that can be cut, sectioned or magnified to see detail. This simulated component can then be animated to show the cutting process, toolpath, metal removal and the finished component checked for accuracy.

ALPHA SYSTEM XS SERIES

Unique control software developed by Colchester/Harrison enables you to double, triple or even quadruple your productivity compared to other turning methods. The reason our Alpha System is so simple, practical and shop floor friendly is that our engineers designed this with the operator in mind. The Alpha System uses easily recognizable screen graphics along with simple question and answer prompts to guide you. It is also the reason that the Alpha System uses a touch screen, so you can work directly on the screen rather than hunt for the right button to press.

Manual Turning

Turn the key and you are turning manually. The manual screen display shows X and Z positions just like a DRO plus spindle speed, tool number and feed rate.

Even if you haven't used a lathe since your schooldays, you could walk up to a MultiTurn now and cut metal.

One of the advantages of the Alpha System is that you are always in control of the machine and you can manually override machining at any time to gain confidence or to hit the optimum tool performance.



Tool Setting

On many lathes, tool setting can be a difficult and tedious process. No lathe control has a simpler tool setting procedure than the Alpha. Just follow the instructions on three screens and the job is done with the machine automatically calculating offsets and workshifts for you. (These offsets will carry over to the manual guide i side).

Semi-Automatic Turning

With the Colchester/Harrison Alpha System, a wide range of semi-automatic turning operations can be performed. These include parallel turning to stop positions, chamfers and radii, tapers, threads, grooves, box cycles and even contour shapes. These operations can be quickly selected to produce complex components quickly and efficiently. With this, the easy to understand shop floor language with touch screen simplicity means that an operator can learn to machine parts quickly.

Most operators will learn to use the Alpha System in less than half a day!

MULTITURN SC SERIES



SIEMENS CONTROL

Clausing/MultiTurn SC Series:

The Siemens CNC Control is a user-friendly control offering SHOPTURN programming, with ISO Conventional G-code also displayed. The extensive use of graphics on the display simplifies complex machining tasks and minimizes set-up time for experienced and beginner operators.

Siemens user friendly conversational CNC controls offer powerful and versatile control features

- SHOPTURN machining step programming
- 10.4" color display
- Minimum block change time 1ms
- 512 tools, 1024 cutting edges
- 8 MB user memory
- 3D CNC simulation for turning
- Multi Repetitive Cycles for automatic finishing, roughing, drilling, threading, and grooving cycles
- Toolpath graphics
- Programmable increments: 0.0001" min / 99.9999" max
- Thread cutting leads: 0.0001" min / 1.0" max
- Thread repair
- Multiple part program storage
- Constant surface speed / Direct RPM programming
- Menu programming format with operator prompts
- Two axes linear and circular interpolation
- Tool inspection
- Inch/metric data input
- Rigid tapping
- Text search
- Full alpha/numeric keyboard
- Background editing
- Decimal point programming
- Optional stop and block skip

SIEMENS CONTROL FOR SC SERIES

Siemens user-friendly conversational CNC controls offer powerful and versatile programming features that minimize set-up time, regardless of the experience level of the operators. Siemens controls permit editing a program while executing another one. They have a profile editor with graphic support to draw contours by entering known measurements right from the blueprint. Constant monitoring of position, velocity, accelerations, and potential interference prevents undesired machining and helps achieve unmatched part-finish and maximum performance of the machine. The tool inspection feature makes the operator's job easier by allowing him to interrupt the program, check the tool condition (replace it if necessary), reposition the axes and then resume the execution of the program.

TOOLING SYSTEMS FOR MULTITURN

High Accuracy Quick Change Tool Post

	Part #	Tool Selection Sq Max	Max Boring Bar Dia.
CNC1000XS/SC	13IDX-BXA	3/4"	3/4"
CNC2000XS/SC	15IDX-CA	1"	1"
CNC3000XS/SC	18IDX-CA	1"	1"
CNC4000XS/SC	21IDX-CA	1-1/4"	1-1/4"

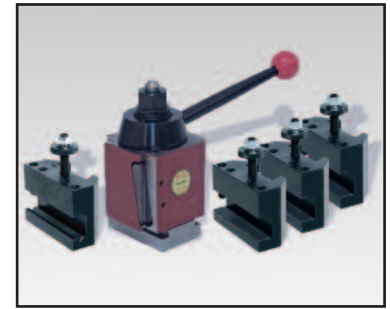

Increase Your Productivity with the Optional Automatic Turret with 0.45 sec. Index Time

Multi-station VDI auto power turret mounted on the front of the cross slide

	Toolholder size	Tool selection	Max boring bar DIA.	No. of stations
CNC1000XS/SC	VDI 30	3/4" (20mm)	1.26" (32mm)	8
CNC2000XS/SC	VDI 30	3/4" (20mm)	1.26" (32mm)	8
CNC3000XS/SC	VDI 30	3/4" (20mm)	1.26" (32mm)	8
CNC4000XS/SC	VDI 30	1" (25mm)	1.57" (40mm)	8

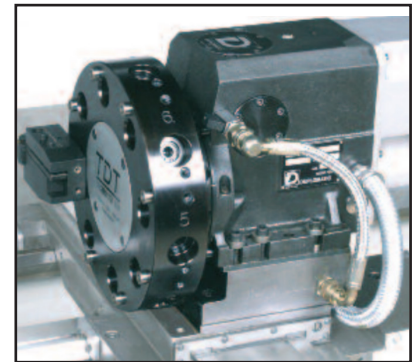

	Disc Diameter	Tooling Type	Shank Size	Max Boring Bar DIA.	No. of Stations
CNC5000XS/SC	14.17"	VDI 50	1" (25mm)	1.26"	8 or 12
CNC6000XS/SC	14.17"	VDI 50	1" (25mm)	1.26"	8 or 12
CNC7000XS/SC	20.7"	VDI 50	1" (25mm)	1.26"	8 or 12

STANDARD EQUIPMENT

- Automatic lubrication system for slideways and ballscrews
- Coolant system
- Fully enclosed, interlocked guarding
- Front removable chip pan
- Work light
- Leveling blocks
- Machine operating manual
- Accuracy chart
- Toolkit
- 230 or 460 3 Phase (other voltage requires transformer or special order)

OPTIONAL EQUIPMENT

- Chip conveyor
- Quick change toolpost
- Automatic turret
- Hydraulic tailstock
- Boring bar holders
- Morse taper tool holders
- Superior precision manual 3 & 4 jaw chucks
- Range of 5C collet chucks and collets
- Range of fixed and traveling steady rests
- Workholding faceplate with guard
- Drive plates
- Choice of manual or automatic tooling systems

Model	CNC1000XS/SC	CNC2000XS/SC	CNC3000XS/SC	CNC4000XS/SC
Capacity				
Swing Over Bed	13.7" (350mm)	15.7" (400mm)	18.1" (460mm)	21.8" (554mm)
Swing Over Cross Slide	7.7" (196mm)	9.7" (246mm)	10.6" (270mm)	14.5" (370mm)
Swing in Gap	21" (535mm)	23" (585mm)	28.7" (730mm)	32.7" (830mm)
Gap Width in Front of Faceplate	6.5" (165mm)	6.5" (165mm)	8.5" (400mm)	8.5" (400mm)
Spindle Center Height from Floor	42.7" (1080mm)	42.7" (1080mm)	45" (1143mm)	47" (1194mm)
Construction				
Width of Cross Slide	7" (178mm)		8" (208mm)	
Type of Cross Slide Ways	Dovetail		Dovetail	
Bed Width	12.5" (320mm)		15.7" (399mm)	
Depth of Bed	15" (380mm)		18" (457mm)	
Type of Bed Ways	V and flat ways		V and flat ways	
Coolant Tank Capacity	20 gallons (75 liters)		25 gallons (95 liters)	
Guarding	Full guarding		Full guarding	
Spindle				
Spindle Nose	D1-4	D1-6	D1-8	D1-11
Spindle Front Bearing I.D.	2.756" (70mm)	3.685" (94mm)	5.25" (133mm)	5.905" (150mm)
Spindle Taper	4 MT	4 MT	5 MT	5 MT
Spindle Bore	1.63" (42mm)	2.16" (55mm)	3.07" (78mm)	4.09" (104mm)
Speed Ranges Automatically Selected	3	3	3	3
Spindle Speed - Low Range	1-366 RPM	1-297 RPM	1-247 RPM	1-224 RPM
Spindle Speed - Medium Range	1-1088 RPM	1-861 RPM	1-740 RPM	1-672 RPM
Spindle Speed - High Range	1-3500 RPM	1-2700 RPM	1-2200 RPM	1-2000 RPM
Spindle Drive	Variable AC	Variable AC	Variable AC	Variable AC
Spindle Motor (continuous/30 min)	7.5/10 Hp (5/7.5 kW)	7.5/10 Hp (5/7.5 kW)	10/15 Hp (7.5/11 kW)	10/15 Hp (7.5/11 kW)
Minimum Speed for Full Power	56 RPM	69 RPM	71 RPM	64 RPM
Power Consumption	22 KVA	22 KVA	26 KVA	26 KVA
Axis				
Cross Slide Travel (X-axis)	9.65" (245mm)		11.7" (310mm)	
X-axis Rapid Traverse	315"/min (8 m/min)		315"/min (8m/min)	
X and Z-axis Feed Rate (inch)	0.0012" - 236"/rev.		0.0012" - 236"/rev.	
X and Z-axis Feed Rate (mm)	0.03" - 60"/rev.		0.03" - 236"/rev.	
X-axis Thrust (continuous)	915 lbs. (415 kg)		1,464 lbs. (664 kg)	
Z-axis Ballscrew	20 x 4mm		25 x 4mm	
Saddle travel (Z-axis)	21.9" (557mm)		55" (1510mm)	
Z-axis Rapid Traverse	394"/min (10m/min)		394"/min (10m/min)	
Z-axis Thrust (continuous)	2,064 lbs. (936 kg)		2,196 lbs. (996 kg)	
Z-axis Ballscrew	32 x 6mm		40 x 8mm	
Positioning Accuracy	± 0.0002" (0.005mm)		± 0.0002" (0.005mm)	
Repeatability	± 0.0001" (0.0025mm)		± 0.0001" (0.0025mm)	
Tailstock				
Tailstock Taper	4 MT	5 MT	6 MT	6 MT
Tailstock Quill Diameter	2.48" (63mm)	2.87" (73mm)	3.74" (95mm)	3.74" (95mm)
Tailstock Quill Travel	5.51" (140mm)	5.51" (140mm)	5.70" (145mm)	5.70" (145mm)

Illustrations and specifications are not binding in detail. The designs are subject to modification and improvement without notice. Workpiece capacity and machinable lengths and diameters will vary and may be reduced below maximum depending on workholding and tooling used. Not all the features described in the brochure are relevant to all machines in the range.

POWER DIAGRAMS

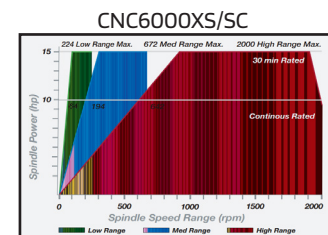
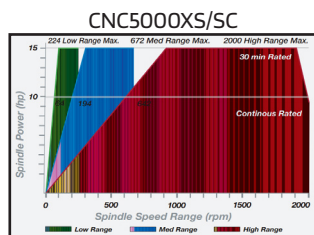
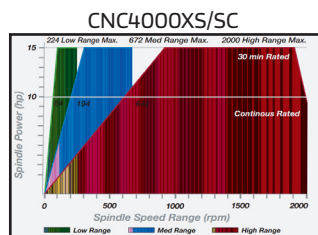
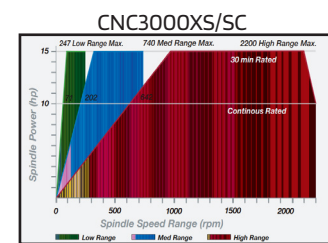
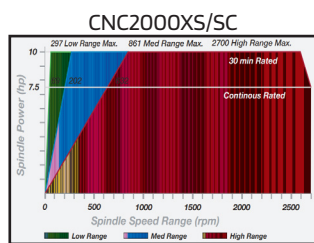
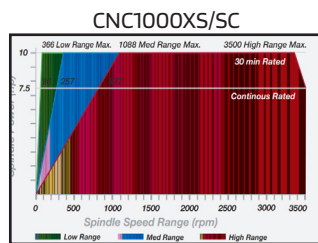

TOOLING OPTIONS

Model	CNC5000XS/SC	CNC6000XS/SC	CNC7000XS/SC
Capacity			
Swing Over Bed	26" (660mm)	30" (762mm)	32" (760mm)
Swing Over Cross Slide	17.87" (454mm)	21.9" (556mm)	23.93" (607mm)
Swing in Gap	37" (940mm)	40.94" (1040mm)	42.9" (1089mm)
Gap Width in Front of Faceplate	11.8" (300mm)	11.8" (300mm)	13.8" (350mm)
Spindle Center Height from Floor	46.65" (1185mm)	48.66" (1236mm)	49.64" (1261mm)
Distance Between Centers	60"/80"/120"/160"/200"/240"	60"/80"/120"/160"/200"/240"	50"/80"/120"/160"/200"/240"
Construction			
Width of Cross Slide	10.2" (259mm)		
Type of Cross Slide Ways	Dovetail		
Bed Width	18.9" (480mm)		
Depth of Bed	17.5" (444mm)		
Type of Bed Ways	V and flat ways		
Coolant Tank Capacity	25 Gallons (95 Liters)		
Spindle			
Standard Spindle Bore	4.13" (105mm)	4.13" (104mm)	4.13" (104mm)
Option 1	6.1" (155mm)	9.05" (230mm)	6.10" (155mm)
Option 2	-	-	9.05" (230mm)
Standard Spindle Nose	D1-11		
Option 1	A2-11		
Option 2	A2-15		
Standard Front Spindle bearing I.D./O.D.	5.905" (150mm)/8.268" (210mm)		
Option 1	7.87" (200mm)/11.02" (280mm)		
Option 2	12" (305mm)/15.5" (394mm)		
Standard Spindle Taper	8 MT		
Option 1	7MT w/Sleeve		
Option 2	3		
Standard Spindle Speed Ranges	N/A		
Low	26 - 224 RPM		
Medium	225 - 670 RPM		
High	671 - 2000 RPM		
Spindle Speed Ranges Option 1	3		
Low	10 - 150 RPM		
Medium	151 - 490 RPM		
High	491 - 1400 RPM		
Spindle Speed Ranges Option 2	3		
Low	4 - 73 RPM		
Medium	74 - 200 RPM		
High	201 - 600 RPM		
Spindle Motor (continious/30min)	20/25 Hp (15/18.kW)		
Power Consumption	26 KVA		
Axis			
Cross Slide Travel (X-axis)	15" (380mm)		
X-axis Rapid Traverse	315"/min (8m/min)		
X-axis Feed Rate	315"/min (8m/min)		
X-axis Thrust (continuous)	1,464 lbs. (644kg)		
X-axis Ballscrew	32mm x 5p		
Z-Axis Travel 60"	57.48"		
80"	77.15"		
120"	117"		
160"	157"		
200"	197"		
240"	237"		
Z-axis Rapid Traverse	276"/min (7m/min)		
Z-axis Feed Rate	276"/min (7m/min)		
Z-axis Thrust (continuous)	2,196 lbs. (996kg)		
Z-axis Ballscrew	50mm x 10p		
Positioning Accuracy	0.0007"		
Repeatability	0.0004"		
Tailstock			
Tailstock Taper	6 MT		
Tailstock Quill Diameter	4.125" (105mm)		
Tailstock Quill Travel	12" (305mm)		

Illustrations and specifications are not binding in detail. The designs are subject to modification and improvement without notice. Workpiece capacity and machinable lengths and diameters will vary and may be reduced below maximum depending on workholding and tooling used. Not all the features described in the brochure are relevant to all machines in the range.

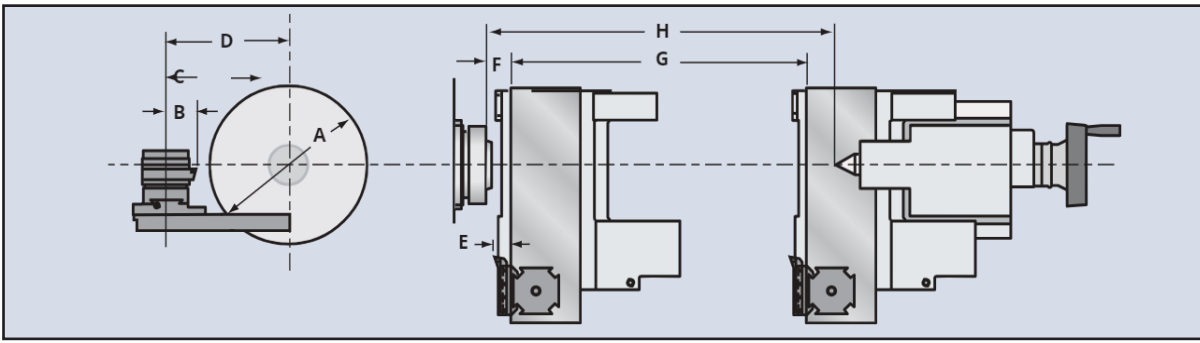

Manual Quick Change Tooling

Model	Center	A	B	C Stroke	D	E	F Min	G	H
CNC1000XS/SC	25" (650mm)	13.78" (350mm)	3.22" (82mm)	9.44" (240mm)	11.43" (291mm)	2.24" (57mm)	3.81" (97mm)	21.93" (557mm)	28" (711mm)
CNC2000XS/SC	50" (1250mm)	15.75" (400mm)	3.22" (82mm)	9.44" (240mm)	11.43" (291mm)	2.24" (57mm)	3.81" (97mm)	45.41" (1156mm)	50.47" (1282mm)
CNC3000XS/SC	60" (1500mm)	18.11" (450mm)	3.54" (90mm)	11.41" (290mm)	14.44" (367mm)	1.69" (43mm)	2.79" (71mm)	59.44" (1510mm)	66.06" (1678mm)
CNC4000/80XS/SC	80" (2000mm)	21.81" (554mm)	3.54" (90mm)	11.41" (290mm)	14.44" (367mm)	1.69" (43mm)	2.44" (62mm)	79.13" (2010mm)	85.39" (2169mm)
CNC4000/120XS/SC	120" (3000mm)	21.81" (554mm)	3.54" (90mm)	11.41" (290mm)	14.44" (367mm)	1.69" (43mm)	2.44" (62mm)	118.5" (3010mm)	124.76" (3169mm)
CNC5000/60XS/SC	60" (1500mm)	18.18" (462mm)	5" (127mm)	15.35" (390mm)	18.62" (473mm)	1.7" (43mm)	5.08" (129mm)	54.76" (129mm)	60.70" (1544mm)
CNC5000/80XS/SC	80" (2300mm)	18.18" (462mm)	5" (127mm)	15.35" (390mm)	18.62" (473mm)	1.7" (43mm)	5.08" (129mm)	74.76" (1890mm)	80.78" (2052mm)
CNC5000/120XS/SC	120" (3000mm)	18.18" (462mm)	5" (127mm)	15.35" (390mm)	18.62" (473mm)	1.7" (43mm)	5.08" (129mm)	114.76" (2915mm)	120.78" (3069mm)
CNC5000/160XS/SC	160" (4000mm)	18.18" (462mm)	5" (127mm)	15.35" (390mm)	18.62" (473mm)	1.7" (43mm)	5.08" (129mm)	154.76" (3931mm)	160.78" (4084mm)
CNC5000/200XS/SC	200" (5080mm)	18.18" (462mm)	5" (127mm)	15.35" (390mm)	18.62" (473mm)	1.7" (43mm)	5.08" (129mm)	194.76" (4947mm)	200.78" (5098mm)
CNC5000/240XS/SC	240" (6096mm)	18.18" (462mm)	5" (127mm)	15.35" (390mm)	18.62" (473mm)	1.7" (43mm)	5.08" (129mm)	234.76" (5963mm)	240.78" (6115mm)
CNC6000/60XS/SC	60" (1500mm)	20.18" (513mm)	5" (127mm)	15.35" (390mm)	18.62" (473mm)	1.7" (43mm)	5.08" (129mm)	54.76" (129mm)	60.70" (1544mm)
CNC6000/80XS/SC	80" (2300mm)	20.18" (513mm)	5" (127mm)	15.35" (390mm)	18.62" (473mm)	1.7" (43mm)	5.08" (129mm)	74.76" (1890mm)	80.78" (2052mm)
CNC6000/120XS/SC	120" (3000mm)	20.18" (513mm)	5" (127mm)	15.35" (390mm)	18.62" (473mm)	1.7" (43mm)	5.08" (129mm)	114.76" (2915mm)	120.78" (3069mm)
CNC6000/160XS/SC	160" (4000mm)	20.18" (513mm)	5" (127mm)	15.35" (390mm)	18.62" (473mm)	1.7" (43mm)	5.08" (129mm)	154.76" (3931mm)	160.78" (4084mm)
CNC6000/200XS/SC	200" (5080mm)	20.18" (513mm)	5" (127mm)	15.35" (390mm)	18.62" (473mm)	1.7" (43mm)	5.08" (129mm)	194.76" (4947mm)	200.78" (5098mm)
CNC6000/240XS/SC	240" (6096mm)	20.18" (513mm)	5" (127mm)	15.35" (390mm)	18.62" (473mm)	1.7" (43mm)	5.08" (129mm)	234.76" (5963mm)	240.78" (6115mm)
CNC7000/60XS/SC	60" (1500mm)	20.18" (513mm)	5" (127mm)	15.35" (390mm)	18.62" (473mm)	1.7" (43mm)	5.08" (129mm)	54.76" (129mm)	60.70" (1544mm)
CNC7000/80XS/SC	80" (2300mm)	20.18" (513mm)	5" (127mm)	18.97" (489mm)	20.9" (530mm)	1.8" (46mm)	7.8" (198mm)	79.5" (2019mm)	79.52" (2020mm)
CNC7000/120XS/SC	120" (3000mm)	20.18" (513mm)	5" (127mm)	18.97" (489mm)	20.9" (530mm)	1.8" (46mm)	7.8" (198mm)	119.5" (3035mm)	119.52" (3035mm)
CNC7000/160XS/SC	160" (4000mm)	20.18" (513mm)	5" (127mm)	18.97" (489mm)	20.9" (530mm)	1.8" (46mm)	7.8" (198mm)	159.5" (4051mm)	159.52" (4051mm)
CNC7000/200XS/SC	200" (5080mm)	20.18" (513mm)	5" (127mm)	18.97" (489mm)	20.9" (530mm)	1.8" (46mm)	7.8" (198mm)	199" (4826mm)	198.9" (5052mm)
CNC7000/240XS/SC	240" (6096mm)	20.18" (513mm)	5" (127mm)	18.97" (489mm)	20.9" (530mm)	1.8" (46mm)	7.8" (198mm)	239" (5842mm)	238" (6045mm)

Automatic Turrets

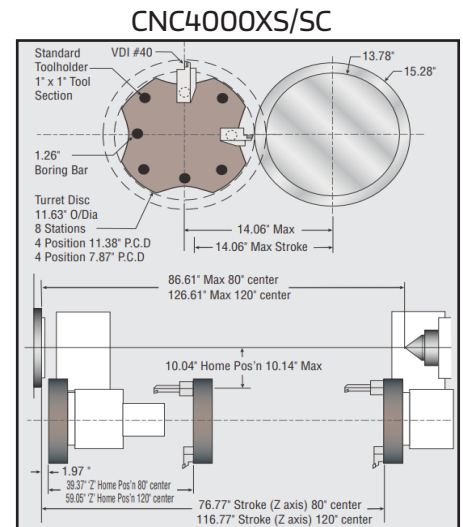
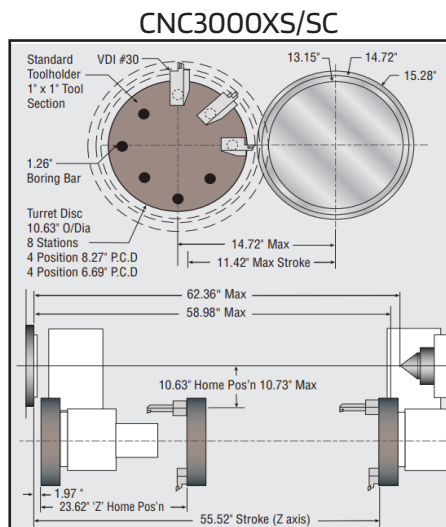
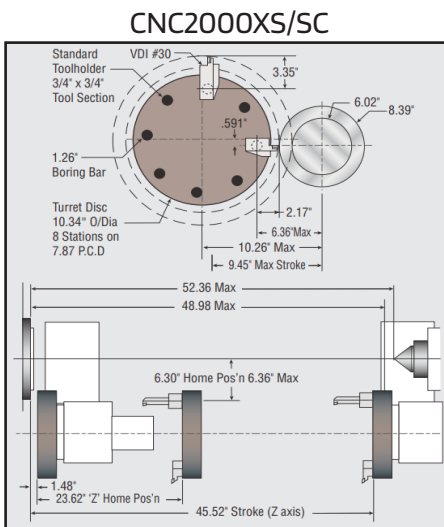

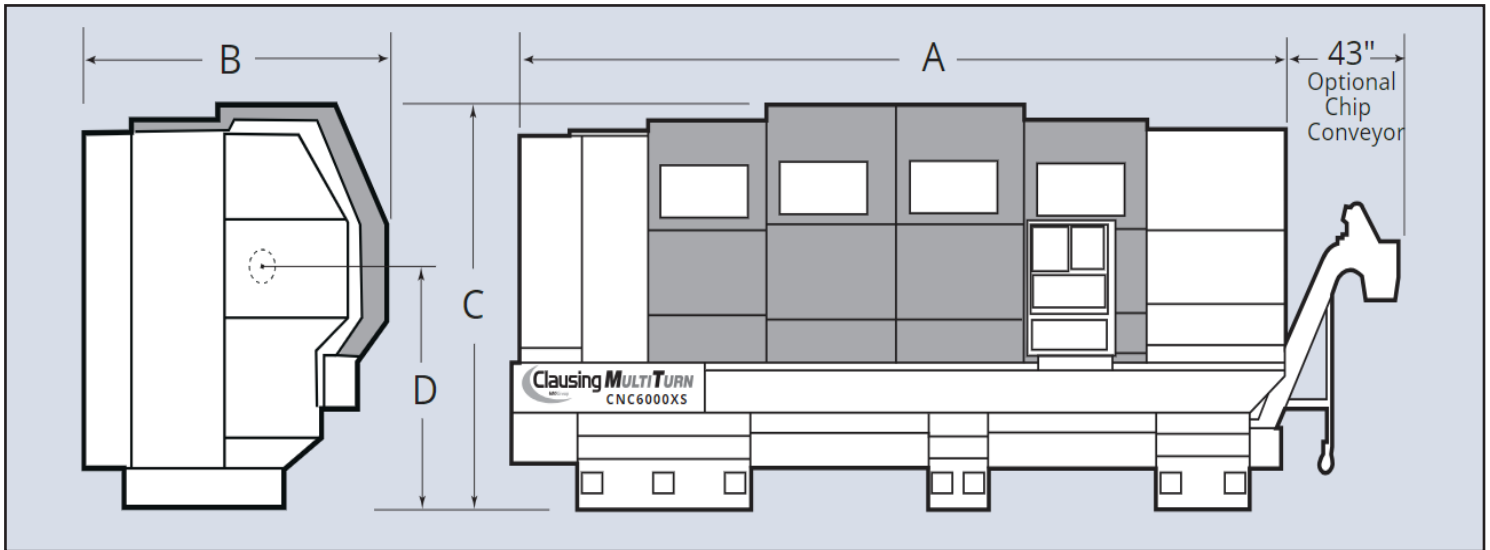

Model	Center	A	B	C Stroke	D	Net Weight	Shipping Weight
CNC1000XS/SC	25" (600mm)	95" (2400mm)	67" (1700mm)	59" (1500mm)	42.7" (1080mm)	3,968 lbs. (1,080kg)	4,200 lbs. (1,905kg)
CNC2000XS/SC	50" (1250mm)	114" (2900mm)	67" (1700mm)	59" (1500mm)	42.7" (1080mm)	4,850 lbs. (2,200kg)	5,200 lbs. (2,358kg)
CNC3000XS/SC	60" (1500mm)	142" (3600mm)	79" (2000mm)	69" (1750mm)	45" (1143mm)	7,054 lbs. (3,200kg)	7,200 lbs. (3,265kg)
CNC4000/80XS/SC	80" (2000mm)	162" (4100mm)	79" (2000mm)	69" (1750mm)	47" (1194mm)	7,937 lbs. (3,600kg)	8,900 lbs. (4,037kg)
CNC4000/120XS/SC	120" (3000mm)	201" (5100mm)	79" (2000mm)	69" (1750mm)	47" (1194mm)	8,818 lbs. (4,000kg)	9,000 lbs. (4,082kg)
CNC5000/60XS/SC	60" (1500mm)	165" (4200mm)	88" (2235mm)	88" (2235mm)	49.6" (1260mm)	9,500 lbs. (4,310kg)	10,830 lbs. (4,912kg)
CNC5000/80XS/SC	80" (2000mm)	185" (4700mm)	88" (2235mm)	88" (2235mm)	49.6" (1260mm)	10,600 lbs. (4,808kg)	12,160 lbs. (5,516kg)
CNC5000/120XS/SC	120" (3000mm)	224" (5690mm)	88" (2235mm)	88" (2235mm)	49.6" (1260mm)	13,250 lbs. (6,010kg)	15,030 lbs. (6,818kg)
CNC5000/160XS/SC	160" (4000mm)	264" (6705mm)	88" (2235mm)	88" (2235mm)	49.6" (1260mm)	15,900 lbs. (7,212kg)	18,130 lbs. (8,224kg)
CNC5000/200XS/SC	200" (5080mm)	304" (7722mm)	92" (2337mm)	88" (2235mm)	49.6" (1260mm)	17,900 lbs. (8,120kg)	20,200 lbs. (9,163kg)
CNC5000/240XS/SC	240" (6069mm)	344" (8738mm)	92" (2337mm)	88" (2235mm)	49.6" (1260mm)	19,900 lbs. (9,027kg)	22,300 lbs. (10,116kg)
CNC6000/60XS/SC	60" (1500mm)	165" (4200mm)	88" (2235mm)	88" (2235mm)	51.6" (1310mm)	9,921 lbs. (4,500kg)	11,270 lbs. (5,112kg)
CNC6000/80XS/SC	80" (2000mm)	185" (4700mm)	88" (2235mm)	88" (2235mm)	51.6" (1310mm)	11,023 lbs. (5,000kg)	12,600 lbs. (5,716kg)
CNC6000/120XS/SC	120" (3000mm)	224" (5690mm)	88" (2235mm)	88" (2235mm)	51.6" (1310mm)	13,669 lbs. (6,200kg)	15,470 lbs. (7,071kg)
CNC6000/160XS/SC	160" (4000mm)	264" (6705mm)	88" (2235mm)	88" (2235mm)	51.6" (1310mm)	16,315 lbs. (7,400kg)	18,570 lbs. (8,423kg)
CNC6000/200XS/SC	200" (5080mm)	304" (7722mm)	92" (2337mm)	88" (2235mm)	51.6" (1310mm)	18,315 lbs. (8,308kg)	20,615 lbs. (9,351kg)
CNC6000/240XS/SC	240" (6069mm)	344" (8738mm)	92" (2337mm)	88" (2235mm)	51.6" (1310mm)	20,315 lbs. (9,215kg)	22,715 lbs. (10,304kg)
CNC7000/60XS/SC	60" (1500mm)	165" (4200mm)	88" (2235mm)	88" (2235mm)	51.6" (1310mm)	9,921 lbs. (4,500kg)	11,270 lbs. (5,112kg)
CNC7000/80XS/SC	80" (2000mm)	175" (4445mm)	80.1" (2035mm)	84.8" (2154mm)	52.3" (1328mm)	17,900 lbs. (8,120kg)	12,600 lbs. (5,716kg)
CNC7000/120XS/SC	120" (3000mm)	218" (5540mm)	82.7" (2035mm)	84.8" (2154mm)	52.3" (1328mm)	19,980 lbs. (9,022kg)	15,470 lbs. (7,071kg)
CNC7000/160XS/SC	160" (4000mm)	246" (6250mm)	82.7" (2035mm)	84.8" (2154mm)	52.3" (1328mm)	21,880 lbs. (9,925kg)	18,570 lbs. (8,423kg)
CNC7000/200XS/SC	200" (5080mm)	285" (7240mm)	82.7" (2035mm)	84.8" (2154mm)	52.3" (1328mm)	23,860 lbs. (10,823kg)	20,615 lbs. (9,351kg)
CNC7000/240XS/SC	240" (6069mm)	326" (8280mm)	82.7" (2035mm)	84.8" (2154mm)	52.3" (1328mm)	25,850 lbs. (11,726kg)	22,715 lbs. (10,304kg)

Large Capacity Automatic Turrets

CNC5000/6000/7000XS/SC

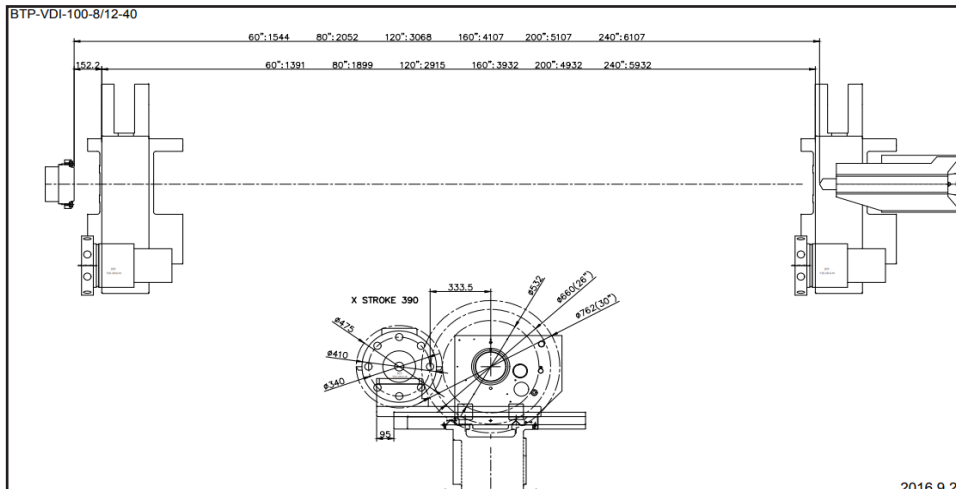

Clausing Industrial

Clausing Industrial, LLC.
Kalamazoo, Michigan
Phone: 800-323-0972
Fax: 269-345-5945
Information: info@clausing-industrial.com
Website: www.clausing-industrial.com



An InCompass™ Brand



manufacturedgrowthsolutions.com